



GbT VPe





GbTVPe

I П бТВPe

4

4

4

4

6

бТВPe



He

97A (TГ g E1	B8BAQD: BППИ	8F8889A7	9: 79CE
; 7E (TГ g 981	B8BAQD: BППИ	8F888; E7	9: 79CE
97 (TГ g 9B1	B8BAQD: BППИ	8F8889: 7	9: 7; :
; 7A (TГ g : 81	A8BAQBE8ППИ	8F888; A7	E7BC
9 (TГ g : B1	A8BAQBE8ППИ	8F889887	E7AE
9(97A TГ g ; : 1	; 8BAQA; BППИ	8F8899A7	A7 A
9(97. TГ g A81	; 8BAQA; BППИ	8F8899: 7	: 79A
: (TГ g B81	: BBAQ; C: BППИ	8F88: 887	: 798
: (97. TГ g CB1	9EBAQ; C9ППИ	8F88: 9: 7	97D
; (TГ g E81	9CBAQ; ; : ППИ	8F88; 887	97A
A (TГ g 9881	9ABAQ; 8; ППИ	8F88A887	97



5 6

5 0

5 : 97. 5; 5A 16

6

Gf 8cS49B8cS

6

Gmh : : E0

Tlg Vg brh : : E RmVg brh : : E16

g

4
gi n 0

6

1

97A 5: 6



GbTVPe

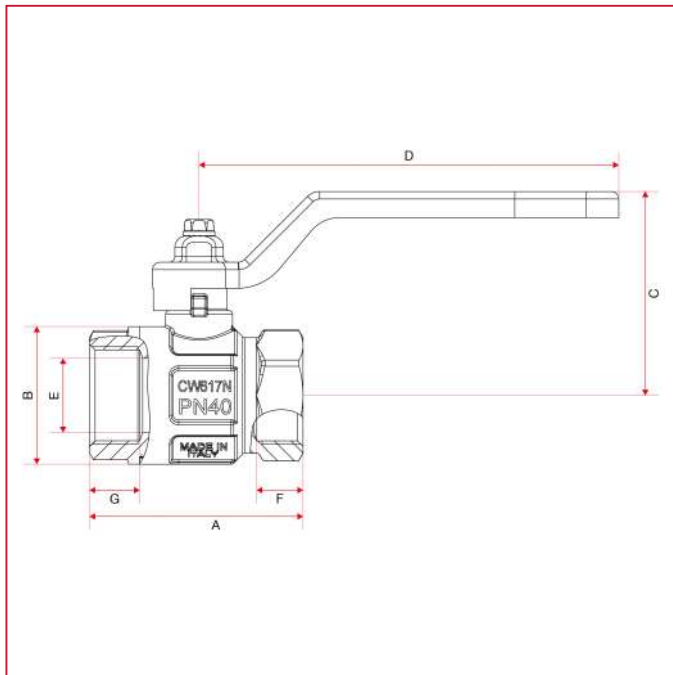

	PDX(TDX(PSX(TDX(P(P(PDX	P(PSX	S(S(PSX	T(X(
Tg	E	98	9B	: 8	: B	; :	A8	B8	CB	E8	988
P	AA4A	AA4A	B84B	BD4B	D8	E84B	FA4B	99: 4B	9; A4B	9BD	9F8
R	: ; 4B	: A	; 84B	; D	AB4B	BD	D8	EA	98F	9; 9	9CA
S	; D	; D	A9	BB	BF	DB	E9	FC	99B	9; ;	9AF
T	E8	E8	E8	99;	99;	9; E	9; E	9BDE	9FD	: B8	: B8
V	98	98	9B	: 8	: B	; :	A8	B8	CB	E8	988
W	98	98	9:	9: 4B	9B	9D	9E4B	::	: A	: C	; 8
X	98	98	9: 4B	9; 4B	9B	9C4B	9D4B	: 84B	: A	: C	; 8
dЖЕМ: БАС	B8	B8	B8	A8	A8	; 8	; 8	: B	9E	9C	9A
eRm5ПТИ	D: B	D: B	D: B	BE8	BE8	A; B	A; B	; C: 4B	: C9	: ;	: 8;



PDX(S(

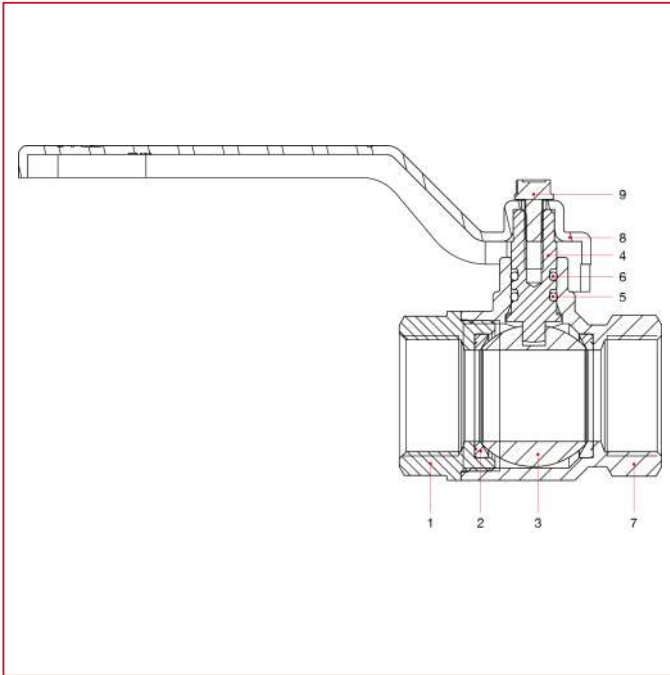

g6		6	
9		9	Sr C9Dg
:		:	
;		9	Sr C9Dg
A		9	Sr C9Ag
B		9	
C		9	pXCh
D		9	Sr C9Dg
E	5	9	8A
F		9	SAS



S(PIB X(

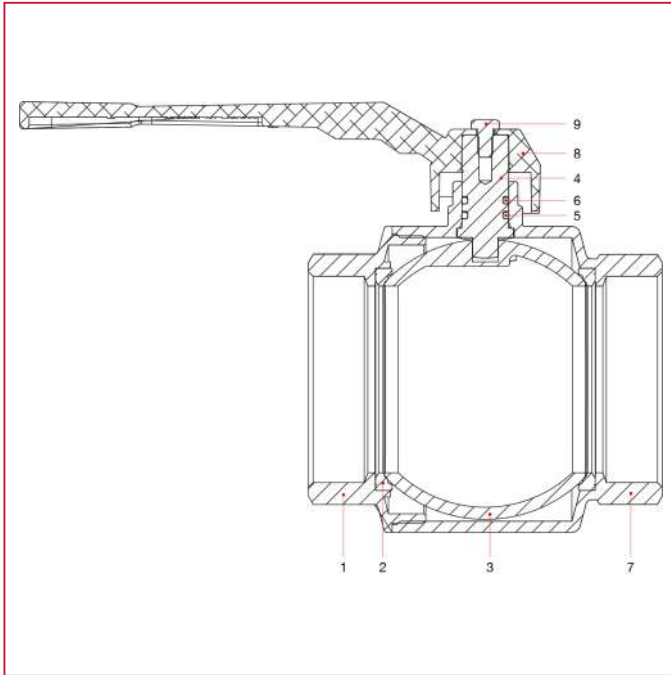

g6		6	
9		9	Sr C9Dg
:		:	
;		9	Sr C9Dg
A		9	Sr C9Ag
B		9	
C		9	p1XCh
D		9	Sr C9Dg
E	5	9	
F		9	SRA VVGS; A1



GtVPe

3 4

dp	97A ; 4AB	; 7E B/B8	97. () 9B4CB	; 7A : C4 C	9(A94AA	9(97A C, 4CF	9(97. 989	: () 9CF	: (97. ; AE	; () ; F8	A(D. B
----	--------------	--------------	------------------	----------------	-------------	-----------------	--------------	--------------	----------------	---------------	------------

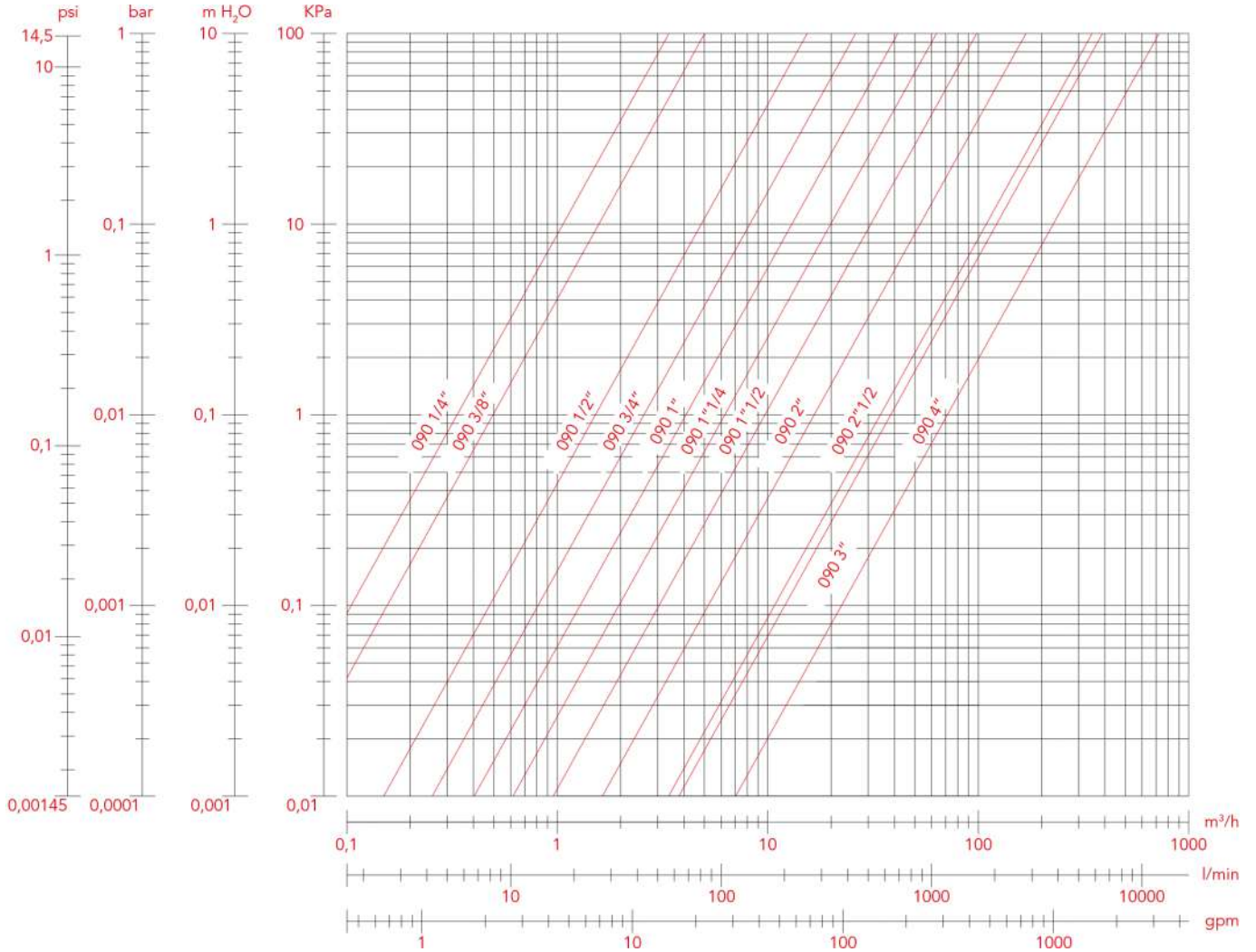



GtVPe

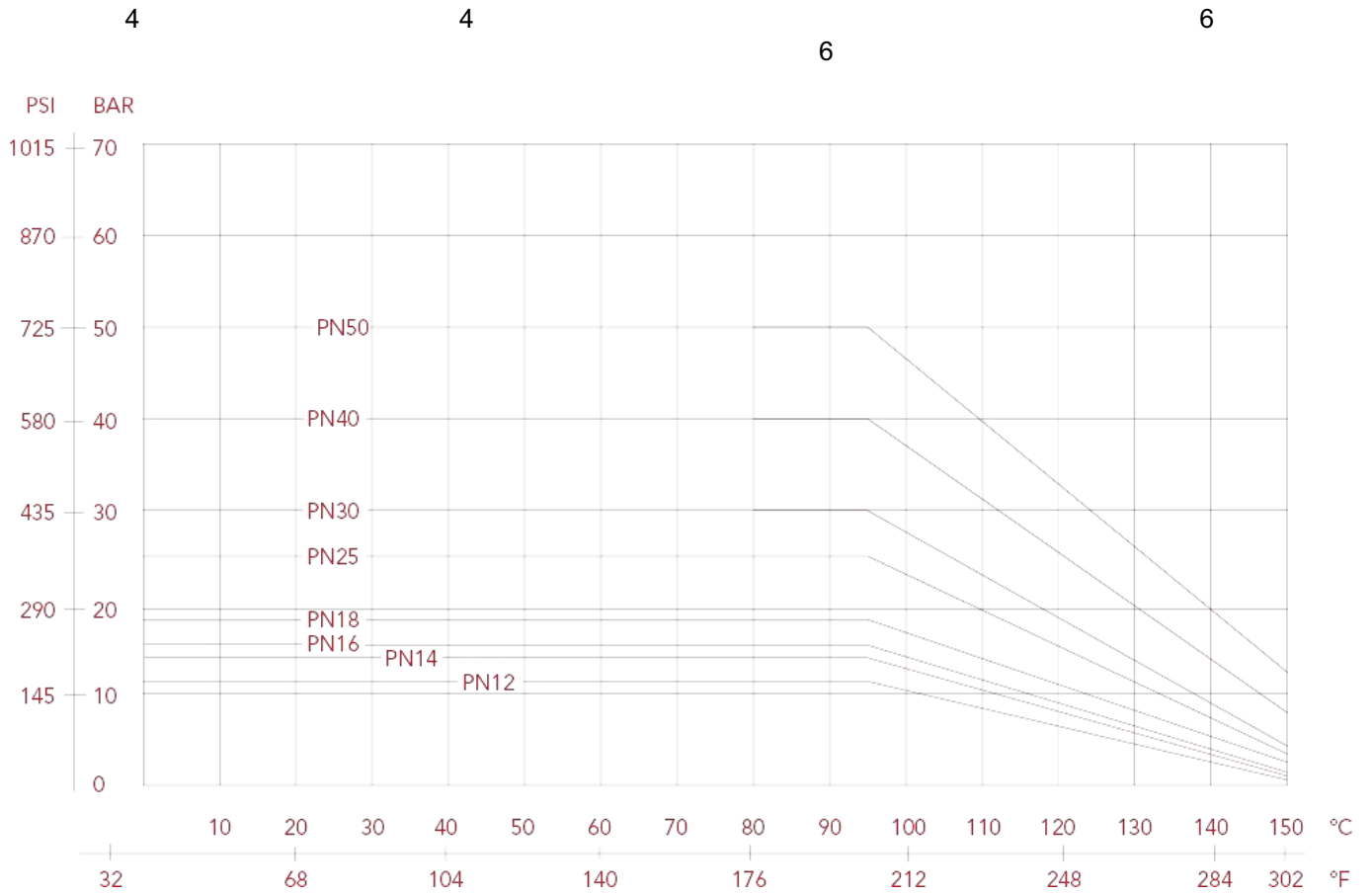



GbTVPe

I GP bTVPe

4

4

4

4

6

bTVPe



He

97A (Tg E1	B8BAQD: BPTI	8F9889Až	9: 9CE
; 7E (Tg 981	B8BAQD: BPTI	8F988; Ež	9: 9CE
97 (Tg 9B1	B8BAQD: BPTI	8F9889: ž	9: 98E
; 7A (Tg : 81	A8BAQBE8PTI	8F988; Až	E7BC
9 (Tg : B1	A8BAQBE8PTI	8F98988ž	E7AE
9(97A Tg ; : 1	; 8BAQA; BPTI	8F9899Až	A7 A
9(97 Tg A81	; 8BAQA; BPTI	8F9899: ž	: 9:
: (Tg B81	: BBAQ; C: BPTI	8F98: 88ž	: 98



5 6

5 6

6

Gf 8cS49B8cS

6

Gmh : : E0
g 4

Tlg Vg brh : : E RmVg brh : : E16
6



GbTVPe

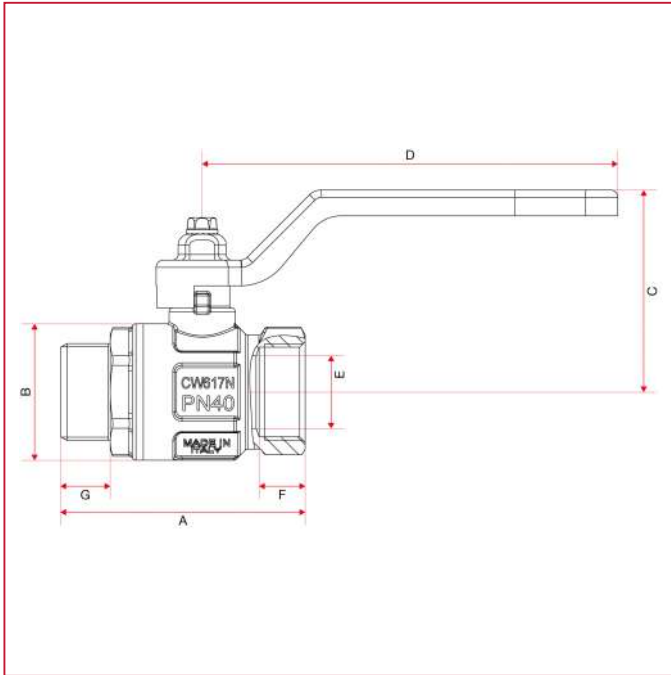

	PDX(TDX(PIS(TDX(P(P(PDX	P(PIS	S(
Tg	E	98	9B	: 8	: B	; :	A8	B8
P	BA	BA	BE4B	CC4B	DE4B	F94B	98B4B	9: :
R	: ; 4B	: A	; 84B	; D	AB4B	BD	D8	EA
S	; D	; D	A9	BB	BF	DB	E9	FC
T	E8	E8	E8	99;	99;	9; E	9; E	9BDE
V	E	98	9B	: 8	: B	; :	; F	B8
W	98	98	9:	9: 4B	9B	9D	9E4B	: :
X	984B	984B	994B	9; 4B	9A4B	9D	9F	: 9
d)ЖЕМ: БАС	B8	B8	B8	A8	A8	; 8	; 8	: B
e)Rm5ПТИ	D: B	D: B	D: B	BE8	BE8	A; B	A; B	; C: 4B

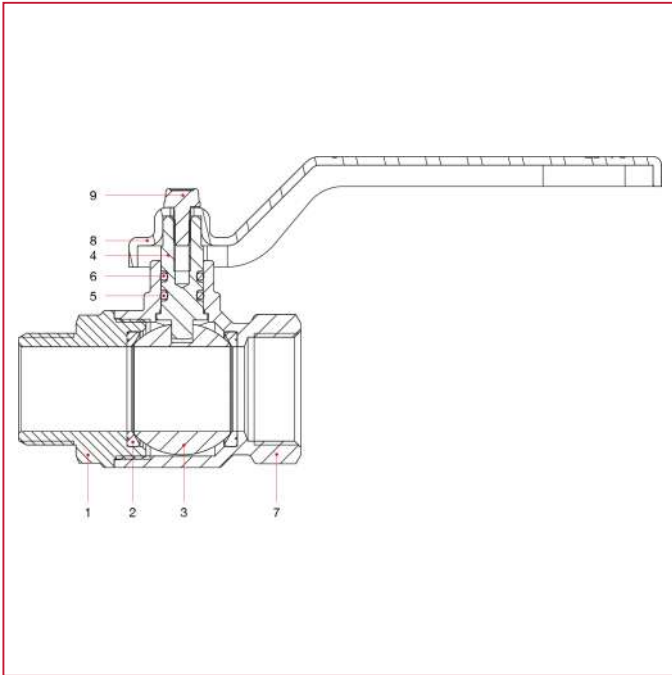

g6		6	
9		9	Sr C9Dg
:		:	
;		9	Sr C9Dg
A		9	Sr C9Ag
B		9	
C		9	p10Ch
D		9	Sr C9Dg
E	5	9	8A
F		9	SAS



GbTVPe

lnPi 4 4 6 4
4 4 4 4
4 4 6 4
4 4 4 4
5 4 0 4 1 4 4 4 4 4 4
5 4 0 4 4 4 4 4 4 4
5 6 4 4 4 4 4 4 4 4
5 4 4 4 4 4 4 4 4 4
5 4 4 4 4 4 4 4 4 4
5 4 4 4 4 4 4 4 4 4
5 H 4 4 4 4 4 4 4 4
5 6 4 4 4 4 4 4 4 4



GT VPe

3 4

	97A ; 4B	; 7E B48	97. () 9B4CB	; 7A : C4 C	9 () A94AA	9(97A) C; 4CF	9(97) 989	: () 9CF
--	-------------	-------------	------------------	----------------	----------------	------------------	--------------	--------------

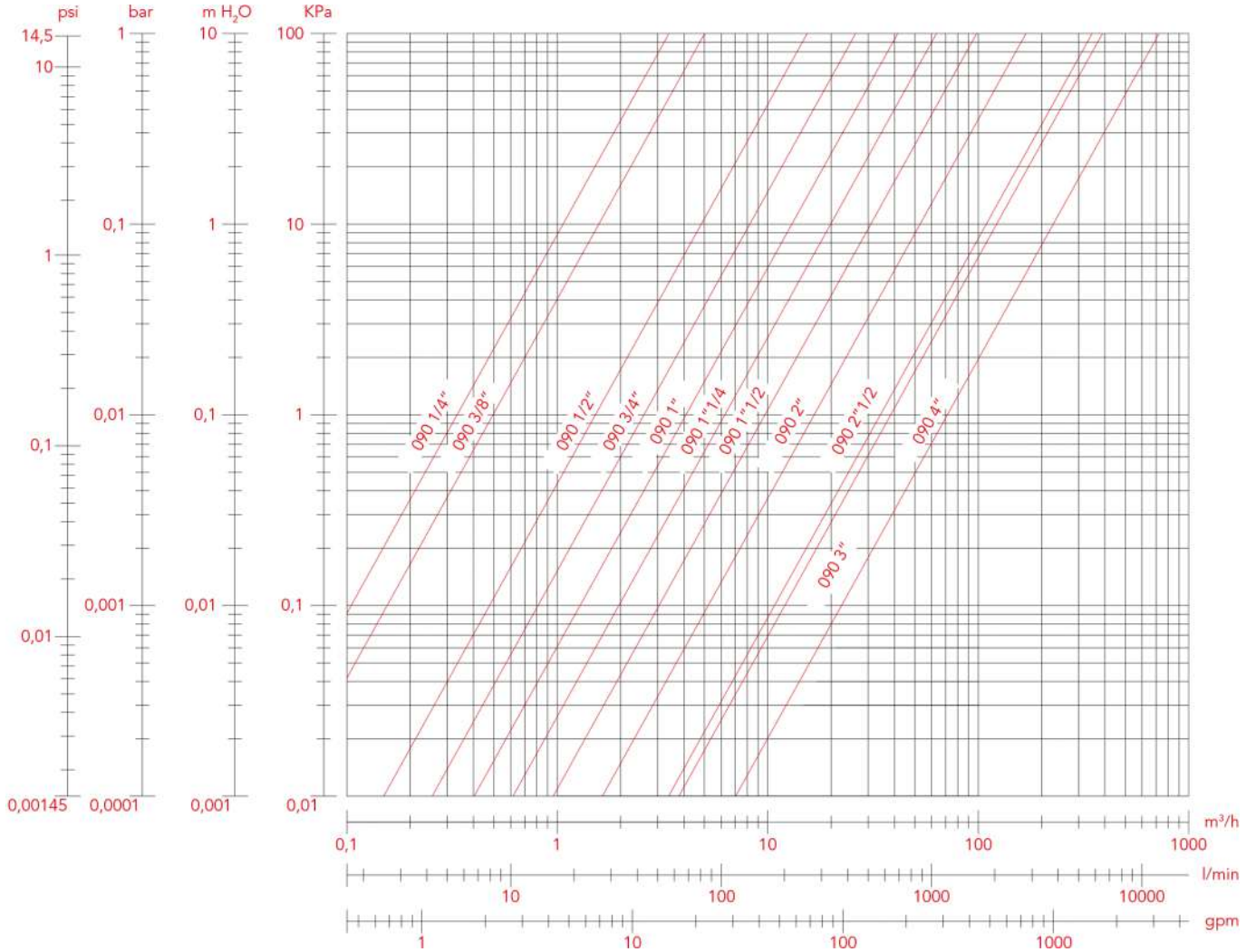



GtVPe

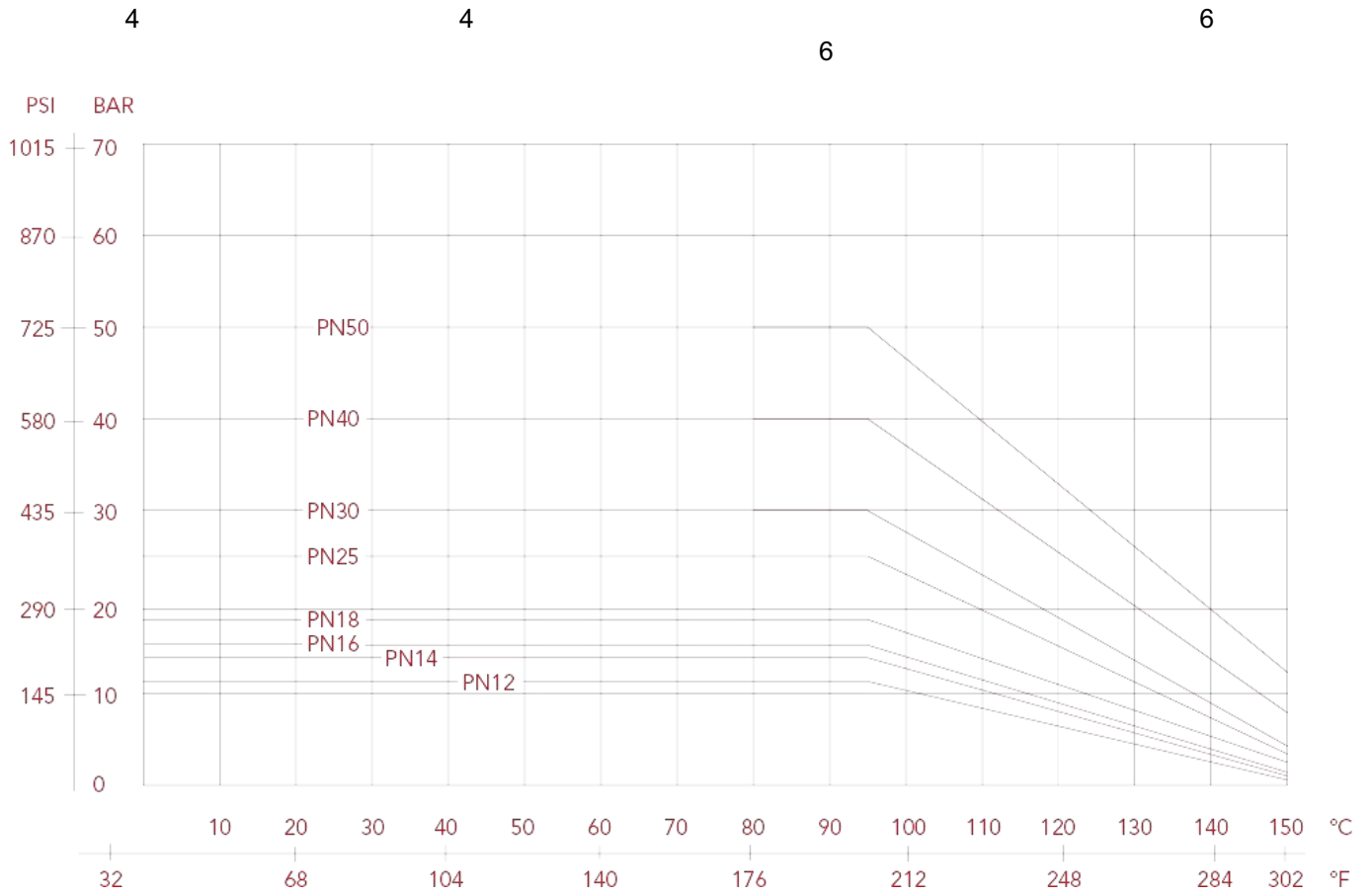



GbTVPe

IGS GbTVPe

4

4

4

4

6

GbTVPe



He

97A (OT g E1	B8BAQD: BГППИ	8F: 889A7	9B7. 98
; 7E (OT g 981	B8BAQD: BГППИ	8F: 88; E7	9B7. 98
97 (OT g 9B1	B8BAQD: BГППИ	8F: 889: 7	9: 7AA
; 7A (OT g : 81	A8BAQBE8ГППИ	8F: 88; A7	E7C
9(OT g : B1	A8BAQBE8ГППИ	8F: 89887	E7C
9(97A OT g ; : 1	; 8BAQA; BГППИ	8F: 899A7	A7 E



5 6

5

6

6

Gf 8cS49B8cS

6

Gmh : : E0
g 4

Tg Vg brh : : E RmVg brh : : E16
6

gi n 0

1

97A 59 6



GbTVPe

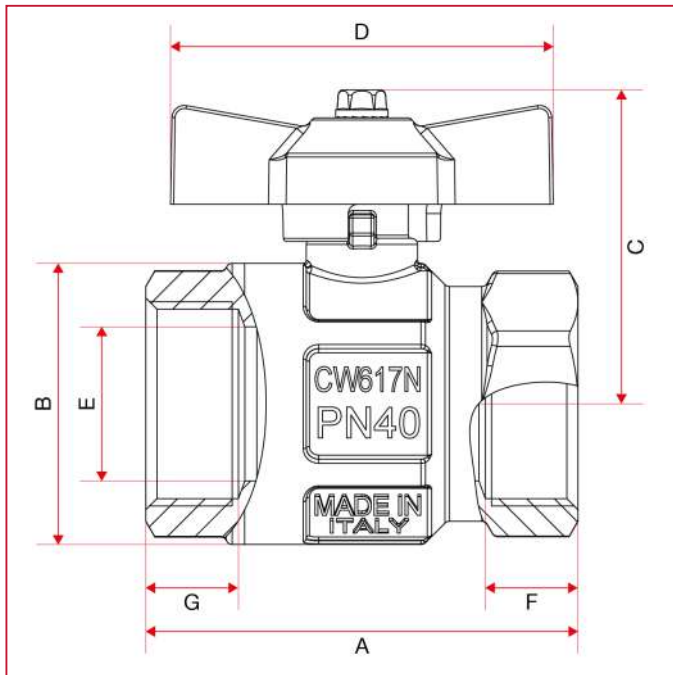

	PDX	TDX	PSX	TDX	P	P(PDX)
Tg	E	98	9B	: 8	: B	; :
P	AA4A	AA4A	B84B	BD4B	D8	E84B
R	: ; 4B	: A	; 84B	; D	AB4B	BD
S	; D	; D	A9	AD	B9	CA
T	AD	AD	AD	C.	C.	D8
V	98	98	9B	: 8	: B	; :
W	98	98	9:	9: 4B	9B	9D
X	98	98	9: 4B	9: 4B	9B	9C4B
dЖЕМ: БАС	B8	B8	B8	A8	A8	; 8
eRm5ПТМ	D: B	D: B	D: B	BE8	BE8	A; B



G6T VPe

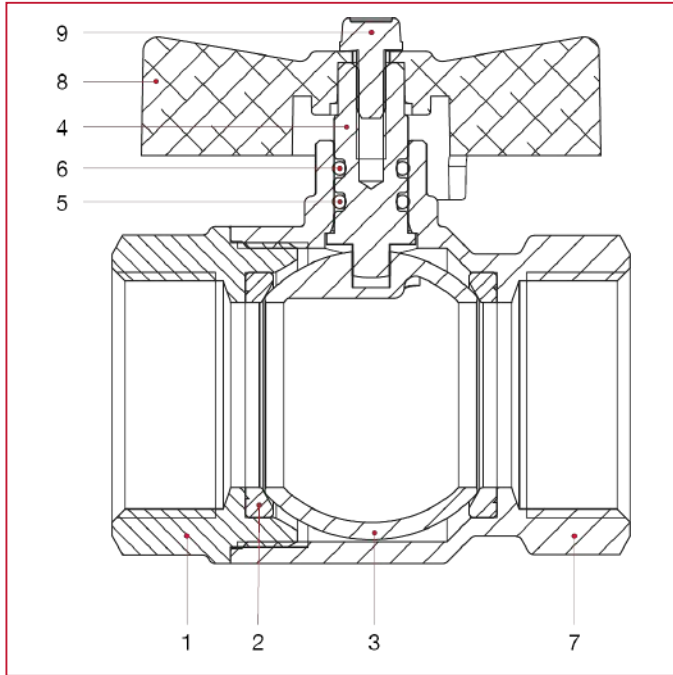

g6		6	
9		9	Sr C9Dg
:		:	
;		9	Sr C9Dg
A		9	Sr C9Ag
B		9	
C		9	pVCH
D		9	Sr C9Dg
E	5	9	
F		9	SAS



GtVPe

3 4

	97A(; 4B	; 7E(B-B8	97. (9B4CB	; 7A(: C4 C	9(A94AA	9(97A C, 4CF
--	-----------	------------	-------------	--------------	----------	--------------

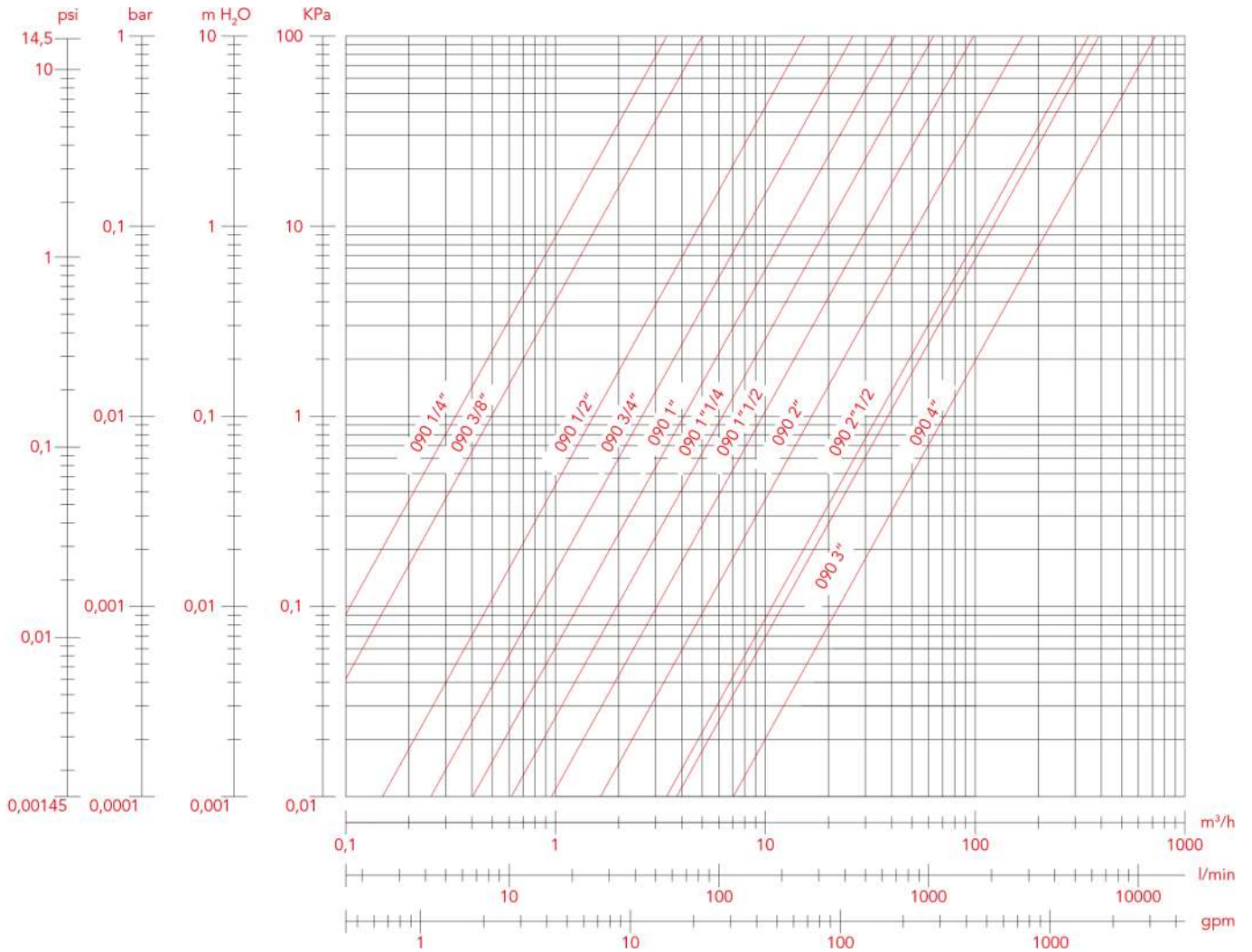



GtVPe

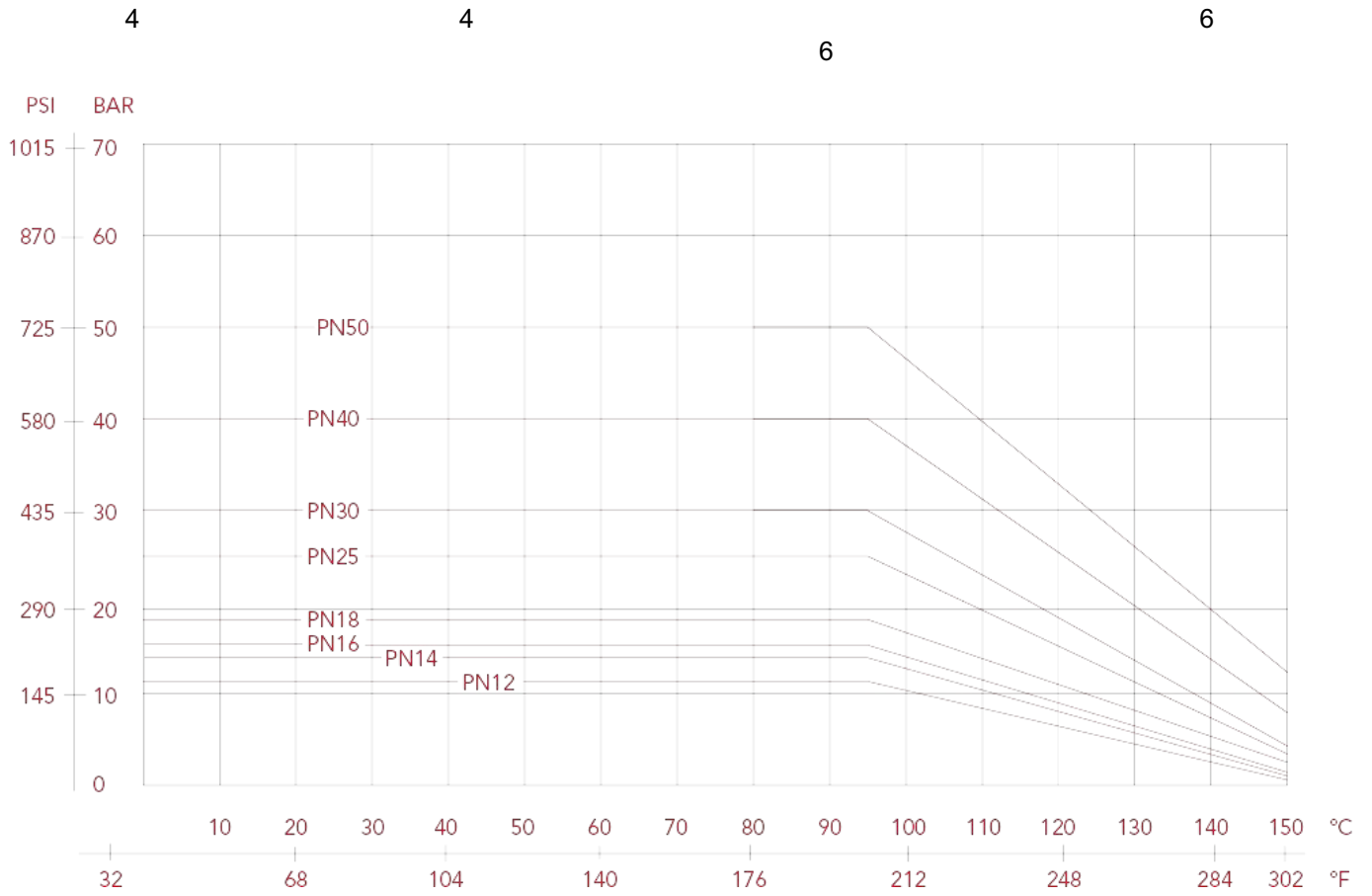



GbTVPe

IIT бТВPe

4

4

4

4

6

бТВPe



He

97A (OT g E1	B8BAQD: BИTИ	8F; 889Aḡ	9B7. 98
; 7E (OT g 981	B8BAQD: BИTИ	8F; 88; Eḡ	9B7ḡFB
97 (OT g 9B1	B8BAQD: BИTИ	8F; 889: ḡ	9: 7ḡ; :
; 7A (OT g : 81	A8BAQBE8ИTИ	8F; 88; Aḡ	E7EE
9(OT g : B1	A8BAQBE8ИTИ	8F; 8988ḡ	E7BC
9(97A OT g ; : 1	; 8BAQA; BИTИ	8F; 899Aḡ	A7 E



5 6

5

6

6

Gḡ 8cS49B8cS

6

Gḡh : : E0
g 4

Tḡ Vg ḡh : : E RmVg ḡh : : E16
6



GbTVPe

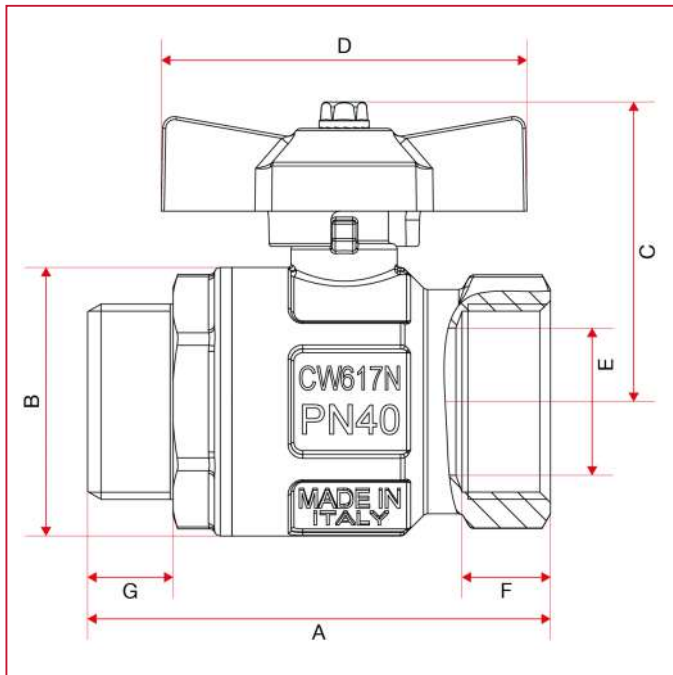

	PDX	TDX	PSX	TDX	P	P(PDX)
Tg	E	98	9B	: 8	: B	; :
P	BA	BA	BE4B	CC4B	DE4B	F94B
R	:: 4B	: A	; 84B	; D	AB4B	BD
S	; D	; D	A9	AD	B9	CA
T	AD	AD	AD	C.	C.	D8
V	E	98	9B	: 8	: B	; :
W	98	98	9:	9: 4B	9B	9D
X	984B	984B	994B	9; 4B	9A4B	9D
dЖЕМ: БАС	B8	B8	B8	A8	A8	; 8
eRm5ПТМ	D. B	D. B	D. B	BE8	BE8	A; B



GbT VPe

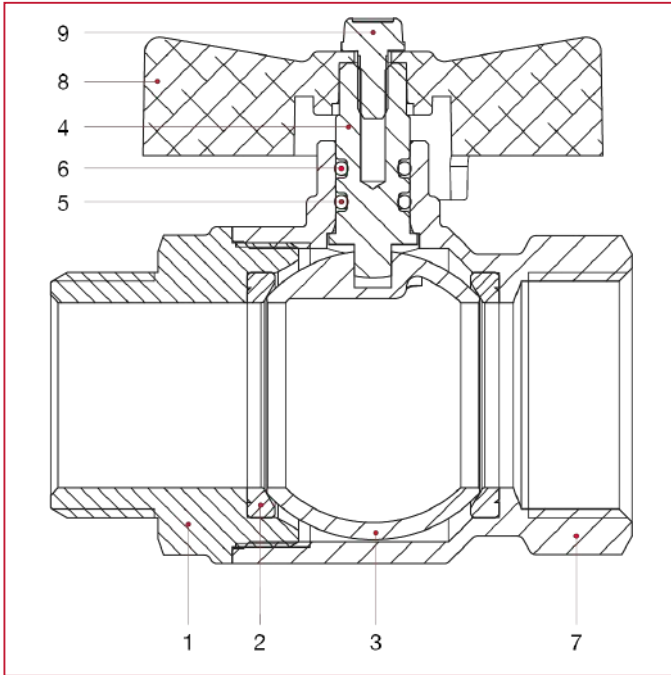

g6		6	
9		9	Sr C9Dg
:		:	
;		9	Sr C9Dg
A		9	Sr C9Ag
B		9	
C		9	p1XCh
D		9	Sr C9Dg
E	5	9	
F		9	SAS



GbTVPe

lnPi 4 4 6 4
4 4 4 4
4 4 6 4
4 4 4 4
5 4 0 4 1 4 4 4 4 4 4
5 4 0 4 4 4 4 4 4 4
5 6 4 4 4 4 4 4 4 4
5 4 4 4 4 4 4 4 4 4
5 4 4 4 4 4 4 4 4 4
5 4 4 4 4 4 4 4 4 4
5 H 4 4 4 4 4 4 4 4
5 6 4 4 4 4 4 4 4 4



GtVPe

3 4

	97A(; 4B	; 7E(B-B8	97. (9B4CB	; 7A(: C4 C	9(A94AA	9(97A C, 4CF
--	-----------	------------	-------------	--------------	----------	--------------

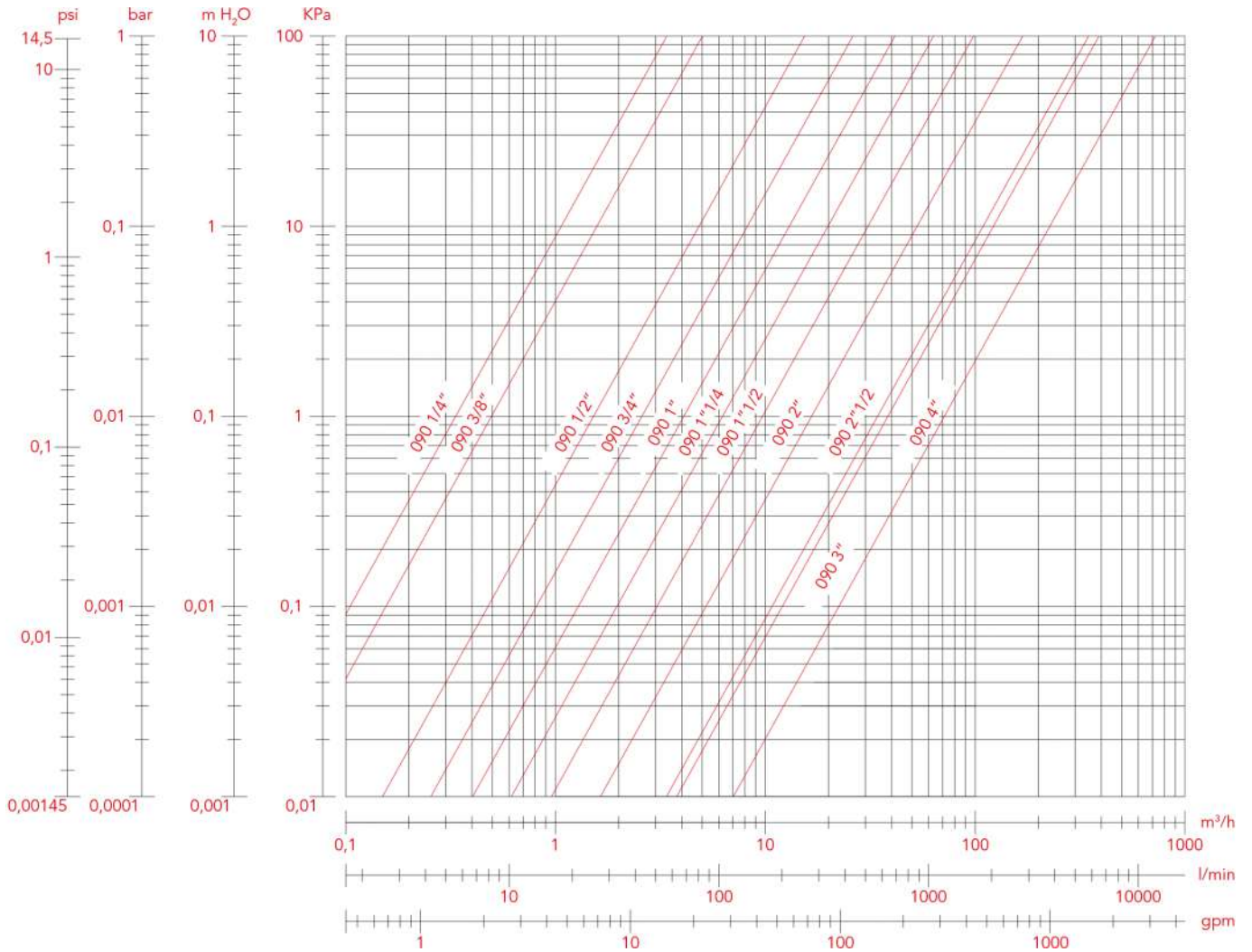



GtVPe

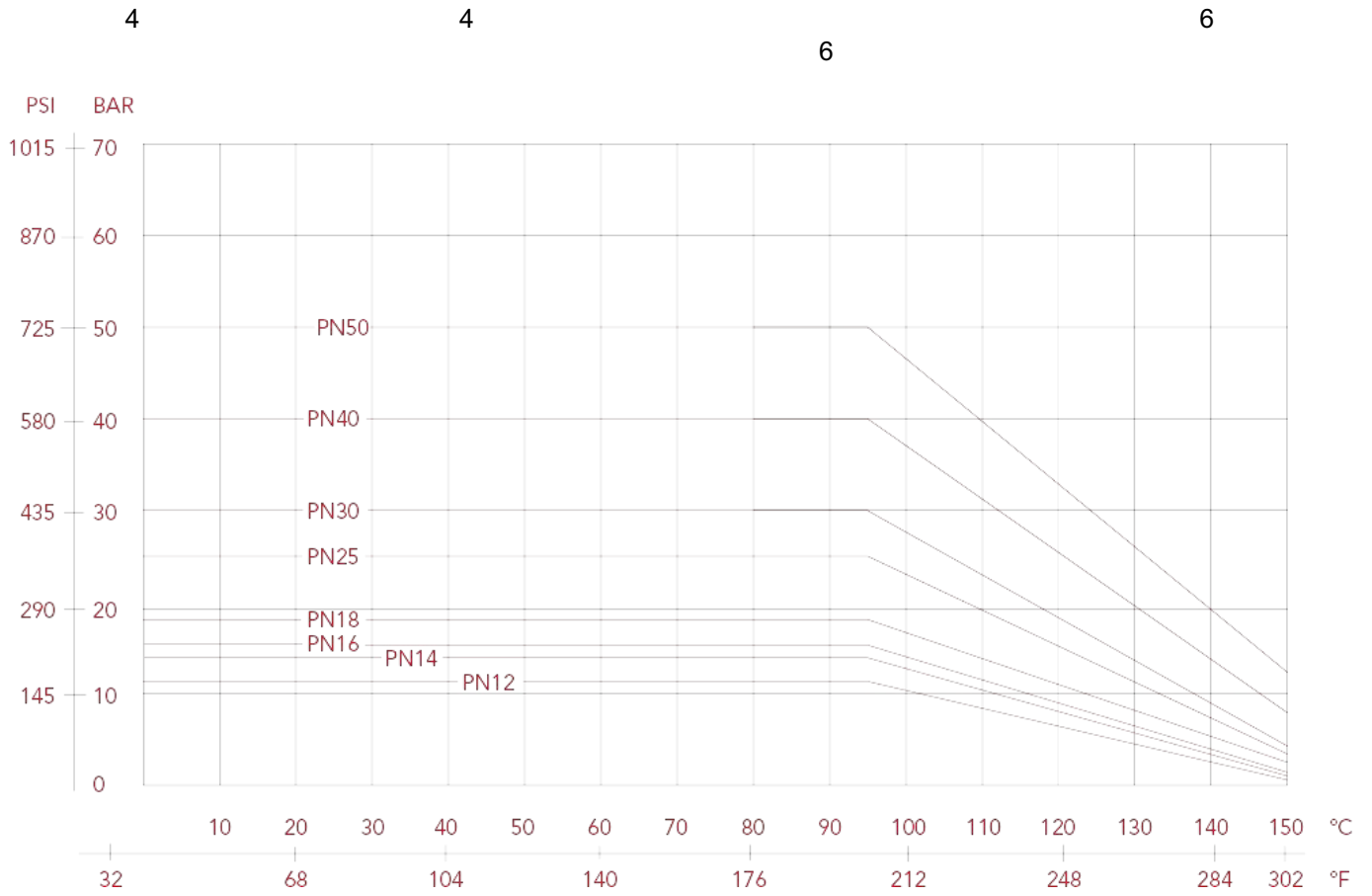



GbTVPe

SGI GbTVPe

4

4

4

4

6

GbTVPe



He

97A (TG E1	B8BAQD: BPTI	: 9C889A	9: 79CE
; 7E (TG 981	B8BAQD: BPTI	: 9C88; E	9: 79CE
97 (TG 9B1	B8BAQD: BPTI	: F8889:	9: 798E
; 7A (TG : 81	A8BAQBE8PTI	: F888; A	E7BC
9(TG : B1	A8BAQBE8PTI	: F88988	CTA:
9(97A TG ; : 1	; 8BAQA; BPTI	: F8899A	A7 A
9(97. TG A81	; 8BAQA; BPTI	: F8899:	: 79:
: (TG B81	: BBAQ; C: BPTI	: F88: 88	: 798



5 6

6
6

Gb 8cS49B8cS

6

Gmh :: E0

Tlg Vg brh :: E RmVg brh :: E16



GbTVPe

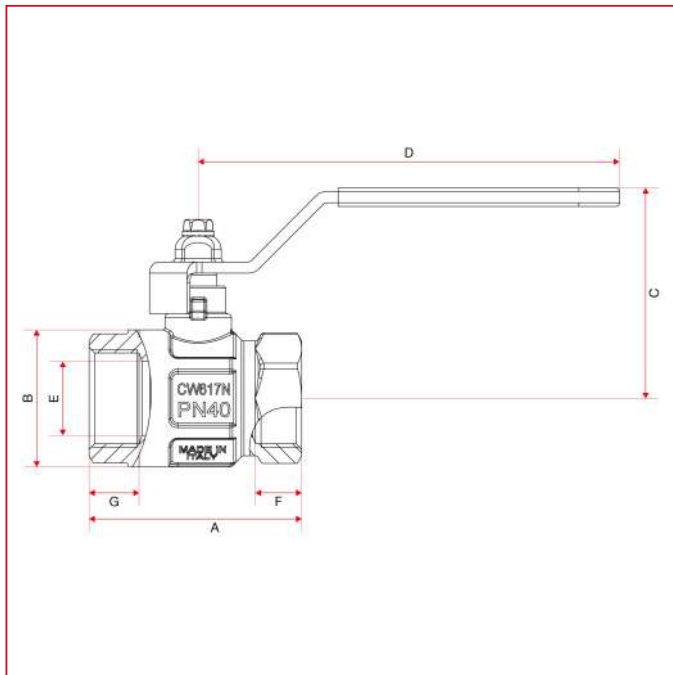

	PDX	TDX	PIS	TDX	P	P(PDX)	P(PIS)	S
Tg	E	98	9B	: 8	: B	; :	A8	B8
P	AA4A	AA4A	B84B	BD4B	D8	E84B	FA4B	99: 4B
R	: ; 4B	: A	; 84B	; D	AB4B	BD	D8	EA
S	A: 4	A: 4	AC4	BC4E	C84E	DC4	E: 4B	FE4
T	EC	EC	EC	99A	99A	9; E4B	9; E4B	9BE4B
V	98	98	9B	: 8	: B	; :	A8	B8
W	98	98	9:	9: 4B	9B	9D	9E	: :
X	98		9: 4B	9; 4B	9B	9C4B	9D4B	: 84B
dЖЕМ: БАС	B8	B8	B8	A8	A8	; 8	; 8	: B
eRm5ПТИ	D: B	D: B	D: B	BE8	BE8	A; B	A; B	; C: 4B

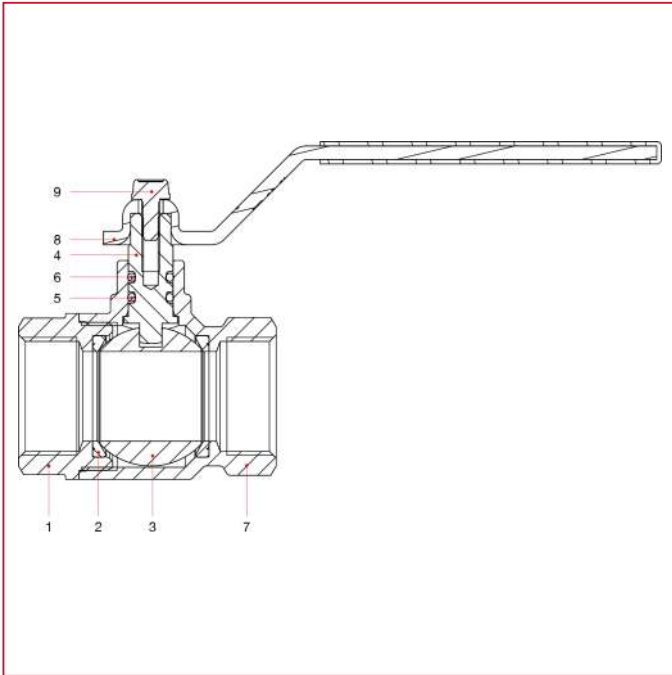

g6		6	
9		9	Sr C9Dg
:		:	
;		9	Sr C9Dg
A		9	Sr C9Ag
B		9	
C		9	p10Ch
D		9	Sr C9Dg
E	5	9	8A
F		9	SAS



GbTVPe

lnPi 4 4 6 4
4 4 4 4
4 4 6 4
4 4 4 4
5 4 0 4 1 4 4 4 4 4 4
5 4 0 4 4 4 4 4 4 4
5 6 4 4 4 4 4 4 4 4
5 4 4 4 4 4 4 4 4 4
5 4 4 4 4 4 4 4 4 4
5 4 4 4 4 4 4 4 4 4
5 H 4 4 4 4 4 4 4 4
5 6 4 4 4 4 4 4 4 4



GT VPe

3 4

	97A(; 7E(97. (; 7A(9(9(97A	9(97	: (
dp	; 4;	AF:	9B4CB	: C4 C	A94AA	C; 4CF	989	9CF

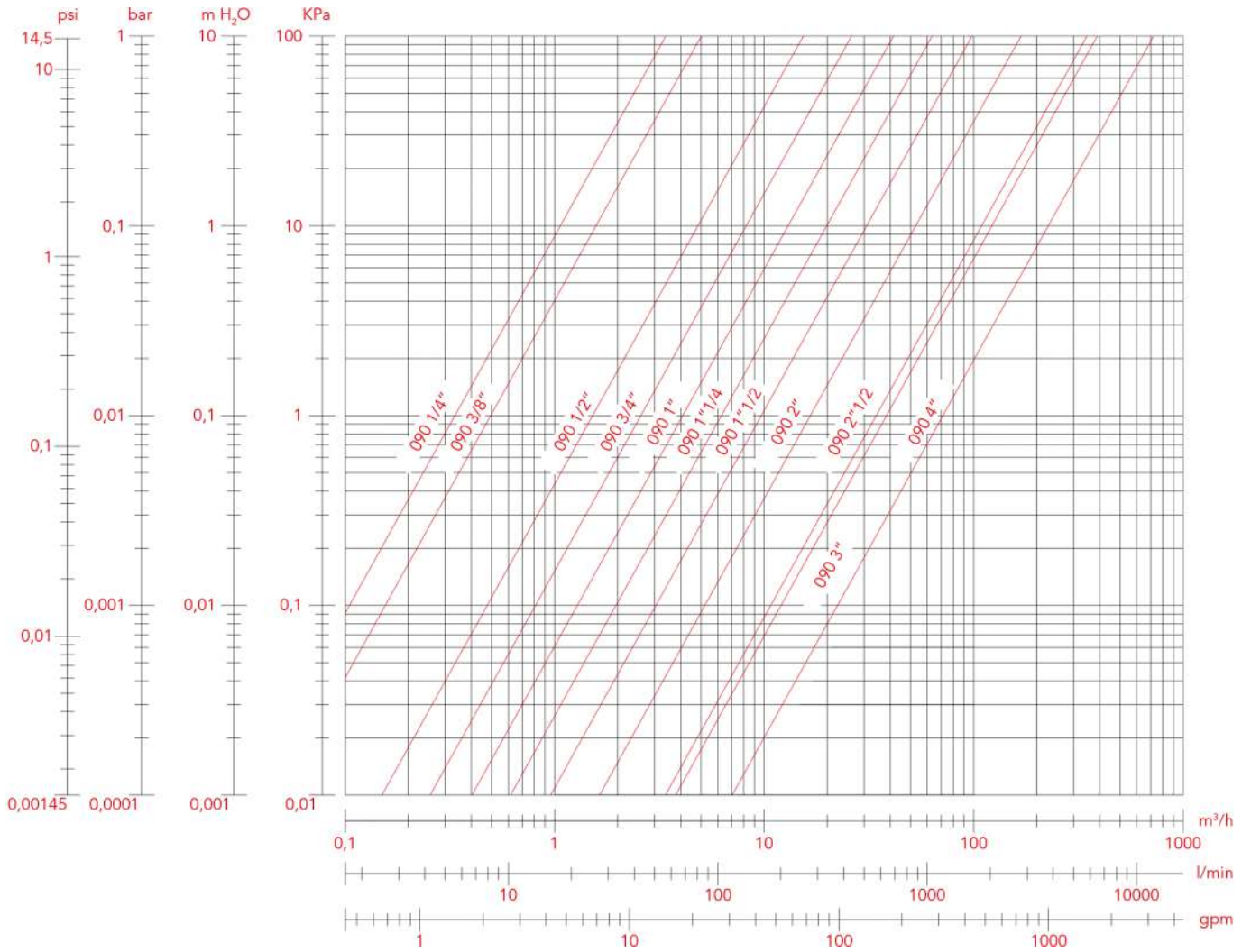



GtVPe

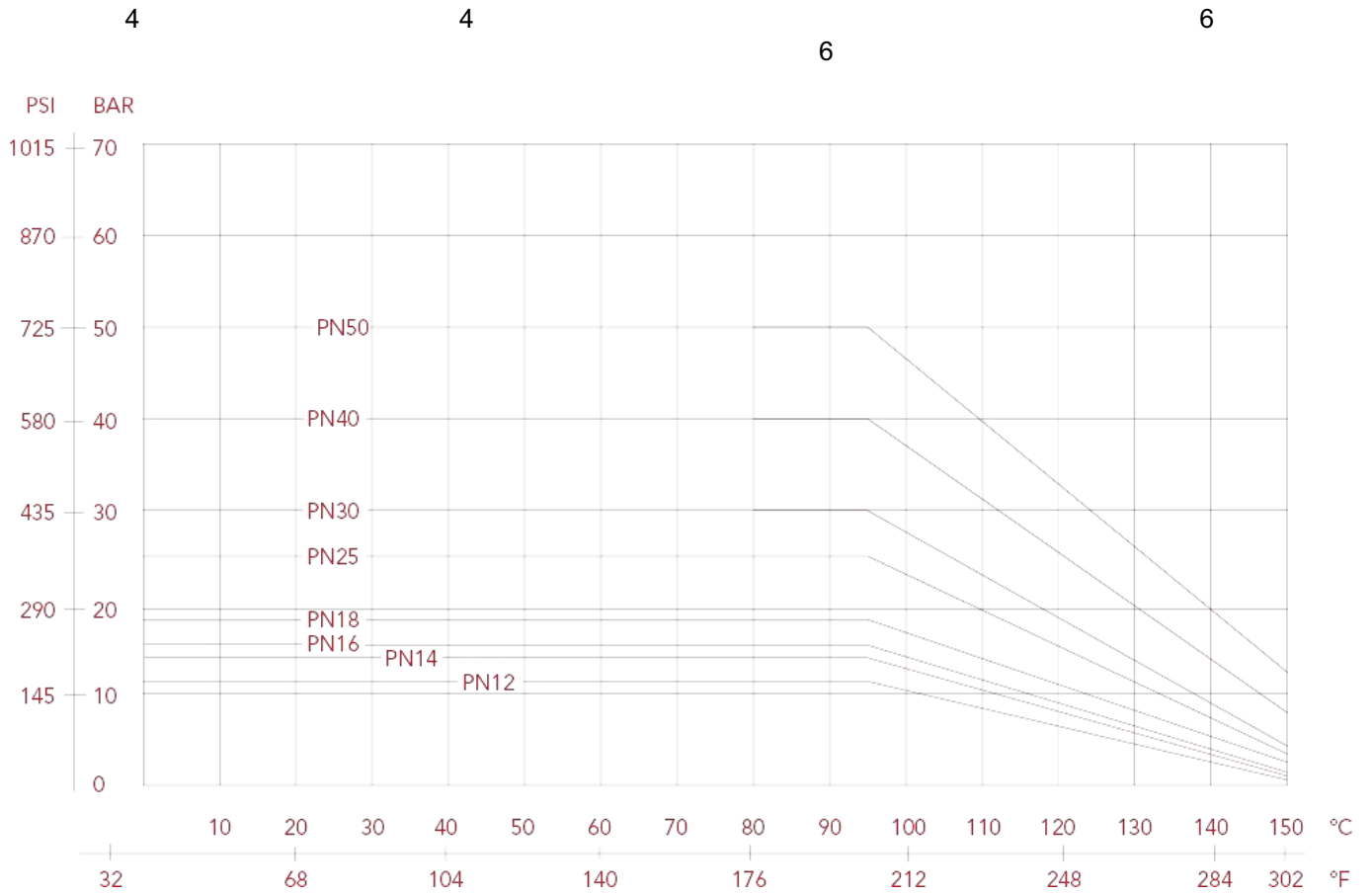



GbTVPe

I GB GbTVPe	4	4		
6		4	4	4



Gb			
97 (Gg 9B1	B8BAQD; BГПП	8FE889:	E79:
; 7A Gg : 81	A8BAQBE8ГПП	8FE88; A	C7BA
9(Gg : B1	A8BAQBE8ГПП	8FE8988	C7, C
9(97A Gg ; : 1	; 8BAQA; BГПП	8FE899A	A7, A
9(97. Gg A81	; 8BAQA; BГПП	8FE899:	: 79:
: (Gg B81	: BBAQ, C; BГПП	8FE8: 88	: 7C



5 6
 5 6
 6
 Gb 8cS49B8cS 6
 Gmh : : E0 Tlg Vg brh : : E RmVg brh : : E16
 9 97 : :



GbTVPe

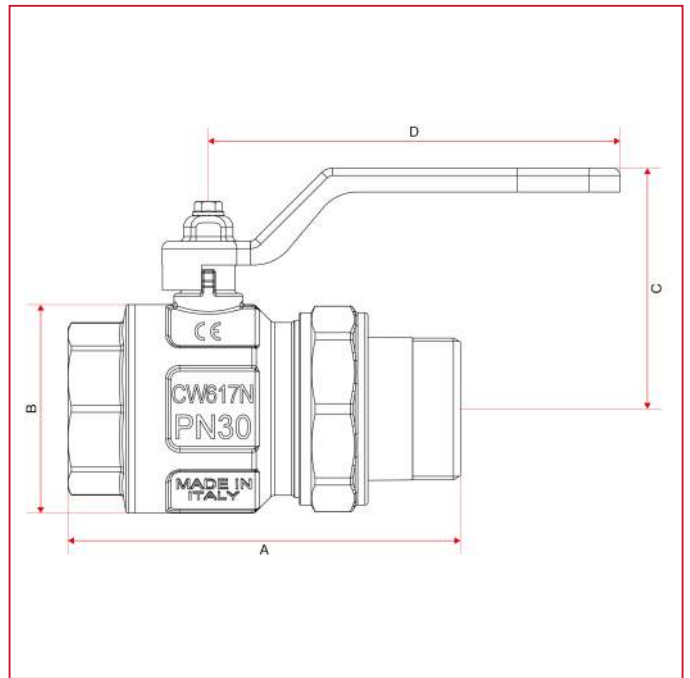
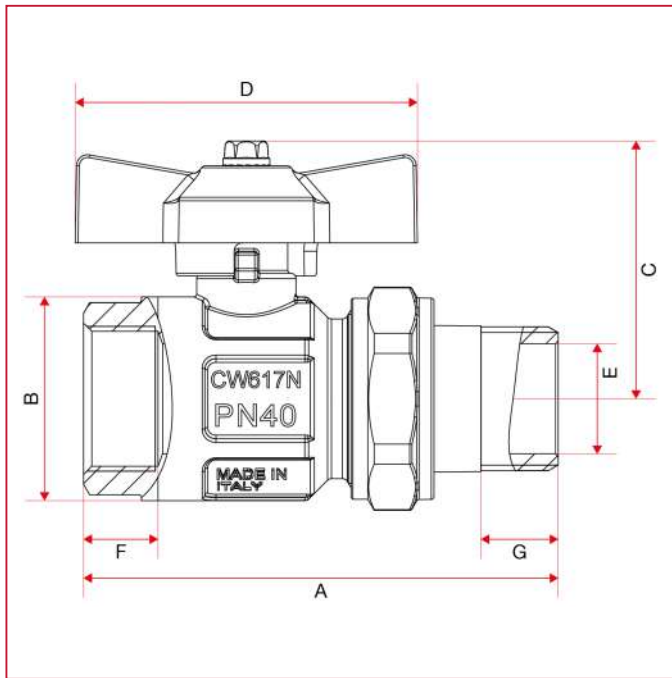

	PLS(TD(P(P(PDX	P(PLS	S(
Tg	9B	: 8	: B	; :	A8	B8
P	DA	EC	FF	99B	9; 94B	9B84B
R	; 84B	; D	AB4B	BD	D8	EA
S	A9	AD	B84E	C; 4B	E9	FC
T	AD	C.	C.	D8	9; E	9BD4E
V	9B	: 8	: B	; :	; F	B8
W	9; 4B	9; 4B	9B	9C4B	9D4B	: 84B
X	9:	9A	9C	9D	9C	9D
d)ЖЕМ: БАС	B8	A8	A8	; 8	; 8	: B
eRm5ПТТ	D; B	BE8	BE8	A; B	A; B	; C; 4B



P15/ P1 PDX

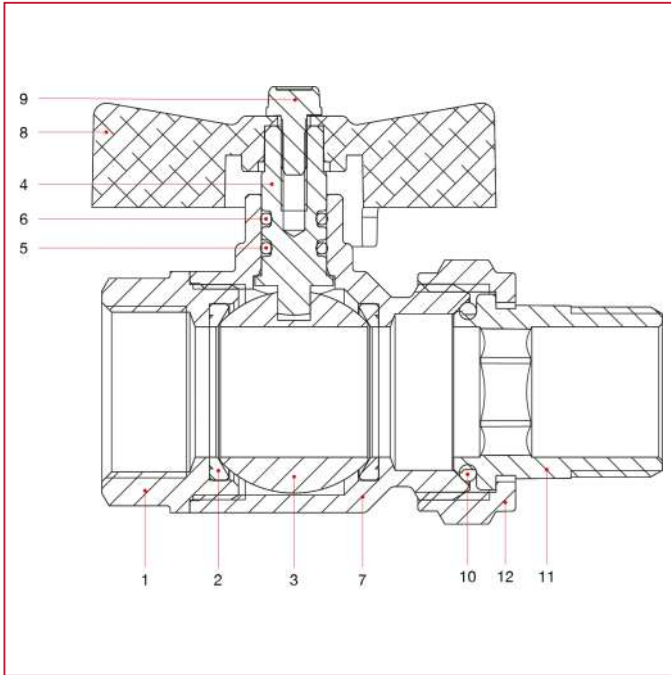

g6		6	
9		9	Sr C9Dg
:		:	
;		9	Sr C9Dg
A		9	Sr C9Ag
B		9	
C		9	p1XCh
D		9	Sr C9Dg
E	5	9	
F		9	SAS
98		9	
99		9	Sr C9Dg
9:		9	Sr C9Dg



P(PS S(

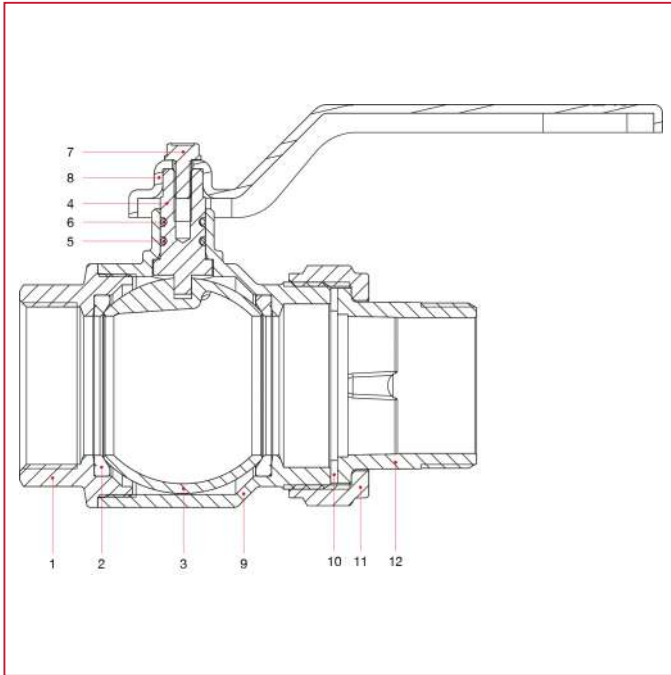

g6		6	
9		9	Sr C9Dg
:		:	
;		9	Sr C9Dg
A		9	Sr C9Ag
B		9	
C		9	pXCh
D		9	SAS
E	5	9	8A
F		9	Sr C9Dg
98		9	
99		9	Sr C9Dg
9:		9	Sr C9Dg



GT VPe

lnPi 4 4 6 4
4 4 4 4
4 4 6 4
4 4 4 4
5 4 0 4 1 4 4 4 4 4
5 0 4 4 4 4 4 4
5 6 4
5 4 4 4 4 4 4
5 5 5 5 5 4 4 4 4
5 H 4 4 4 4 4 4
5 6 4 4 4 4 4 4



GtVPe

3 4

dp	97 (9B4CB	; 7(: C4 C	9(A94AA	9(97A C; 4CF	9(97 989	: (9CF
----	------------	-------------	----------	--------------	----------	---------

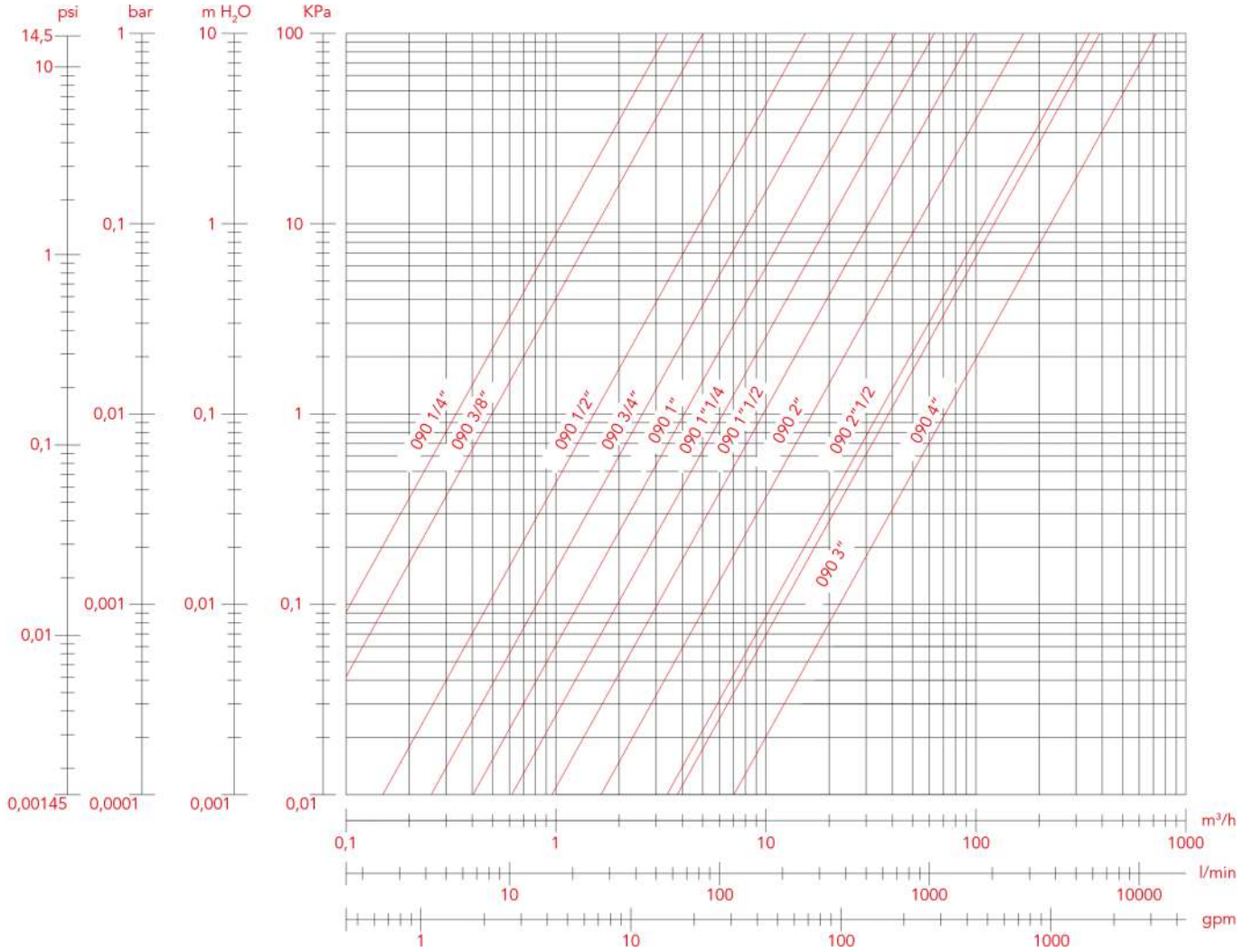



GtVPe

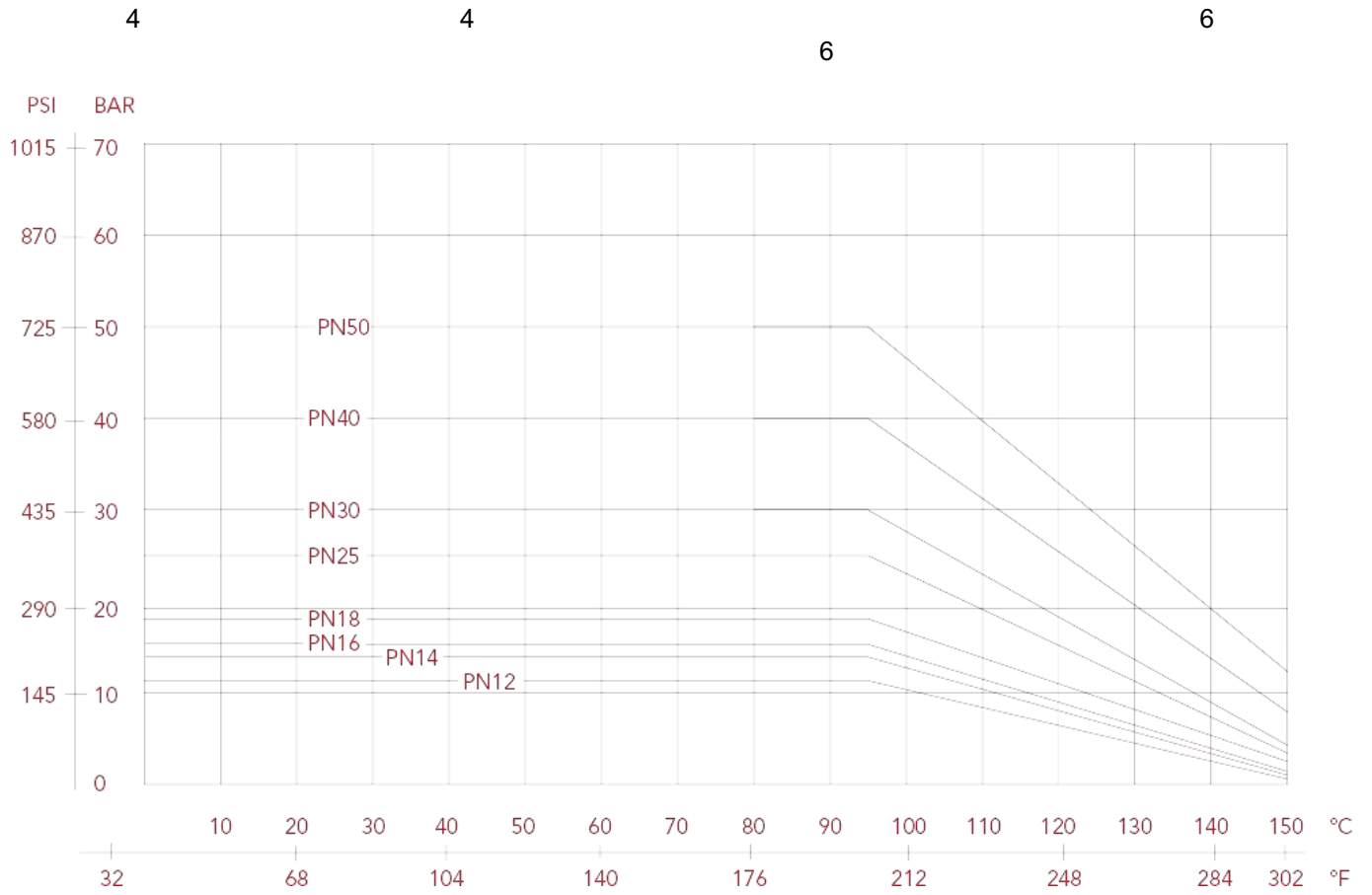



GbT VPe

I GBM	bT VPe	4	4	4
6			4	4
				4



He			
97. (OT g 9B1	B8BAQD; BTTM	8FE889: m	E798A
; 7A(OT g : 81	A8BAQBE8TTM	8FE88; Am7mR	C7CC
; 7A(s9(OT g : 81	A8BAQBE8TTM	8FE88; A988m7mR	C7CC
9(OT g : B1	A8BAQBE8TTM	8FE8988m7mR	C7A:
9(97A OT g ; : 1	; 8BAQA; BTTM	8FE899Am	A7. A

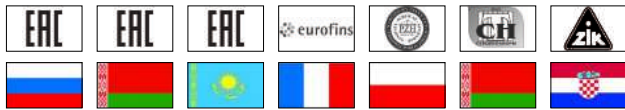

5 6
 5 6
 6
 Gf 8cS49B8cS 6
 Gmh :: E0 Tlg Vg brh :: E RmVg brh :: E16
 ; 7A 9 G mR 4 6
 mR 4
 8FE88; A988mG 7A Ri U ai 6



GtVPe

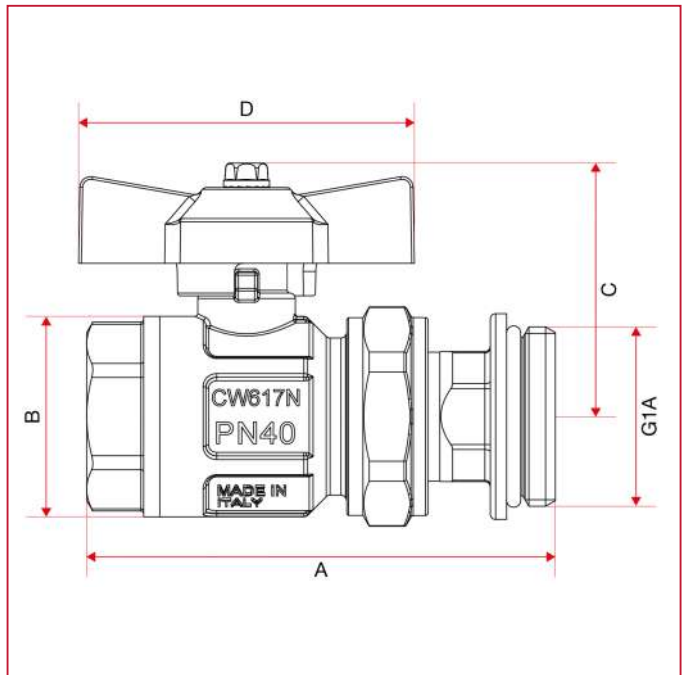
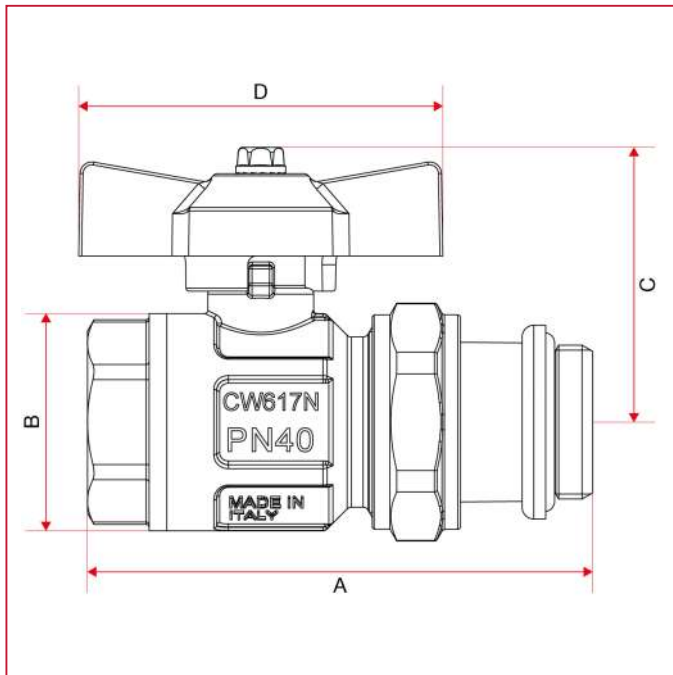

	PIS(TD(TD(bP(P(P(PDX
Tg	9B	: 8	: 8	: B	; ;
P	DA	EC	ECB	FE	99;
R	; 8B	; D	; D	ABB	BD
S	A9	AD	AD	B8E	C; B
T	AD	C.	C.	C.	D8
dЖEM: БAC	B8	A8	A8	A8	; 8
eRm5TTI	D; B	BE8	BE8	BE8	A; B

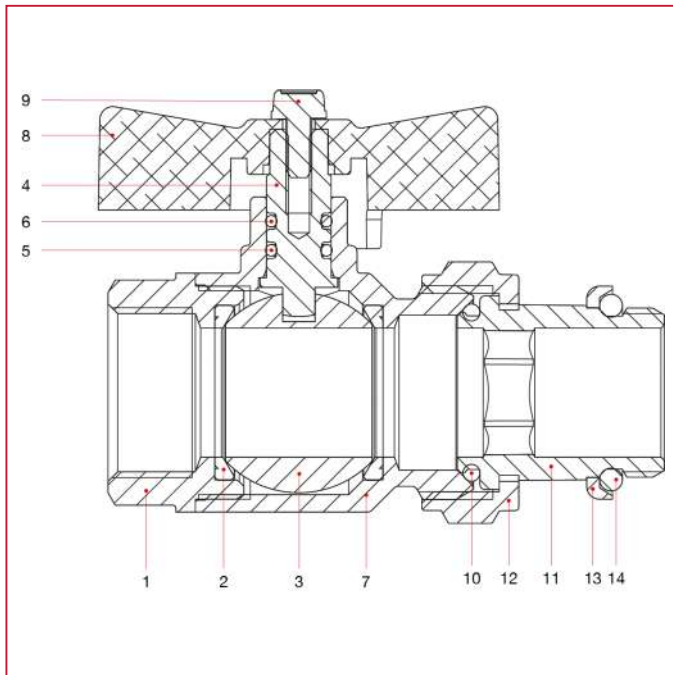

g6		6	
9		9	Sr C9Dg
:		:	
;		9	Sr C9Dg
A		9	Sr C9Ag
B		9	
C		9	p10Ch
D		9	Sr C9Dg
E	5	9	
F		9	SAS
98		9	
99		9	Sr C9Dg
9:		9	
9;		9	
9A		9	Sr C9Dg



TDX P(

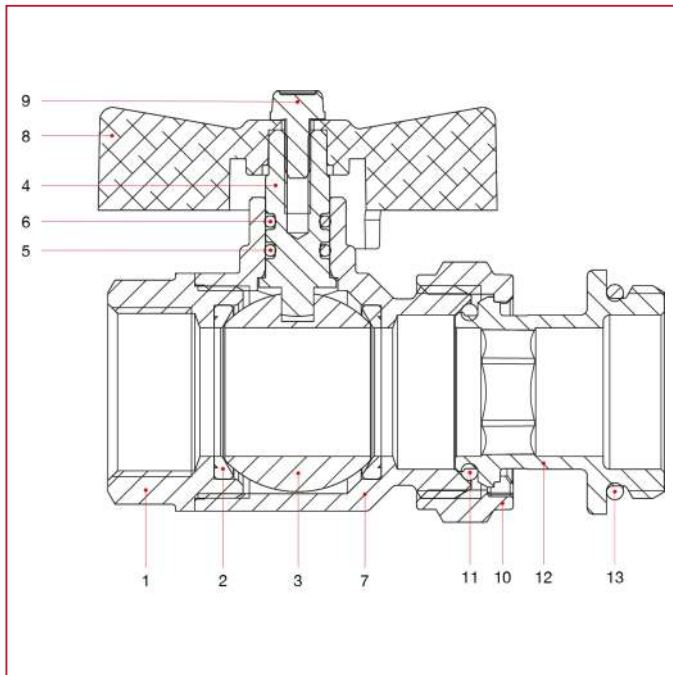

g6		6	
9		9	Sr C9Dg
:		:	
;		9	Sr C9Dg
A		9	Sr C9Ag
B		9	
C		9	p1XCh
D		9	Sr C9Dg
E	5	9	
F		9	SAS
98		9	Sr C9Dg
99		9	
9:		9	Sr C9Dg
9;		9	



GbTVPe

lnPi 4 4 6 4
4 4 4 4
4 4 6 4
4 4 4 4
5 4 0 4 1 4 4 4 4 4 4
5 4 0 4 4 4 4 4 4 4
5 6 4 4 4 4 4 4 4 4
5 4 4 4 4 4 4 4 4 4
5 5 5 5 5 4 4 4 4 4
5 H 4 4 4 4 4 4 4 4
5 6 4 4 4 4 4 4 4 4



GtVPe

3 4

	97 (; 7A(; 7A(s 9(9(9(97A
dp	9B4CB	: C4 C	: C4 C	A94A	C; 4CF

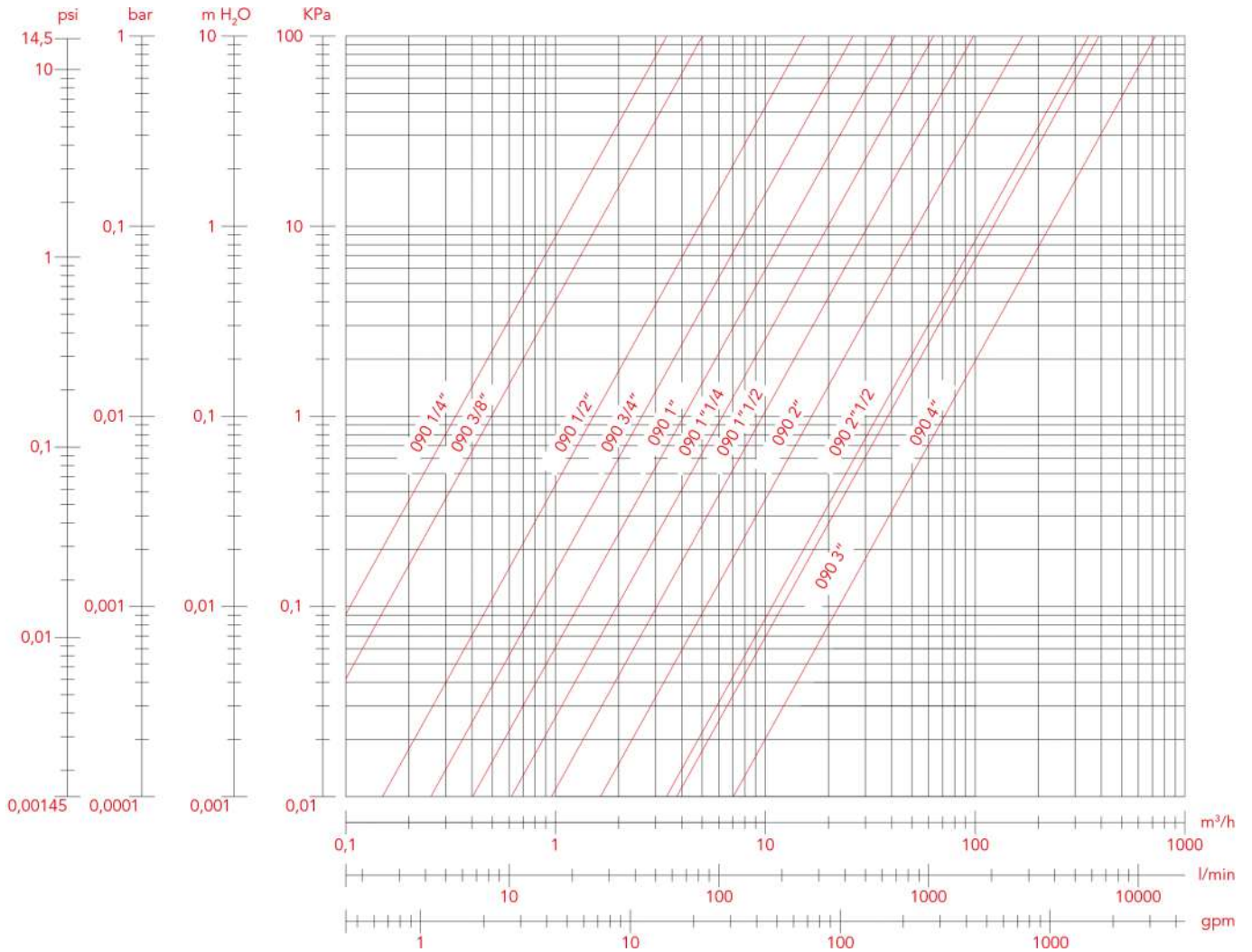



GtVPe

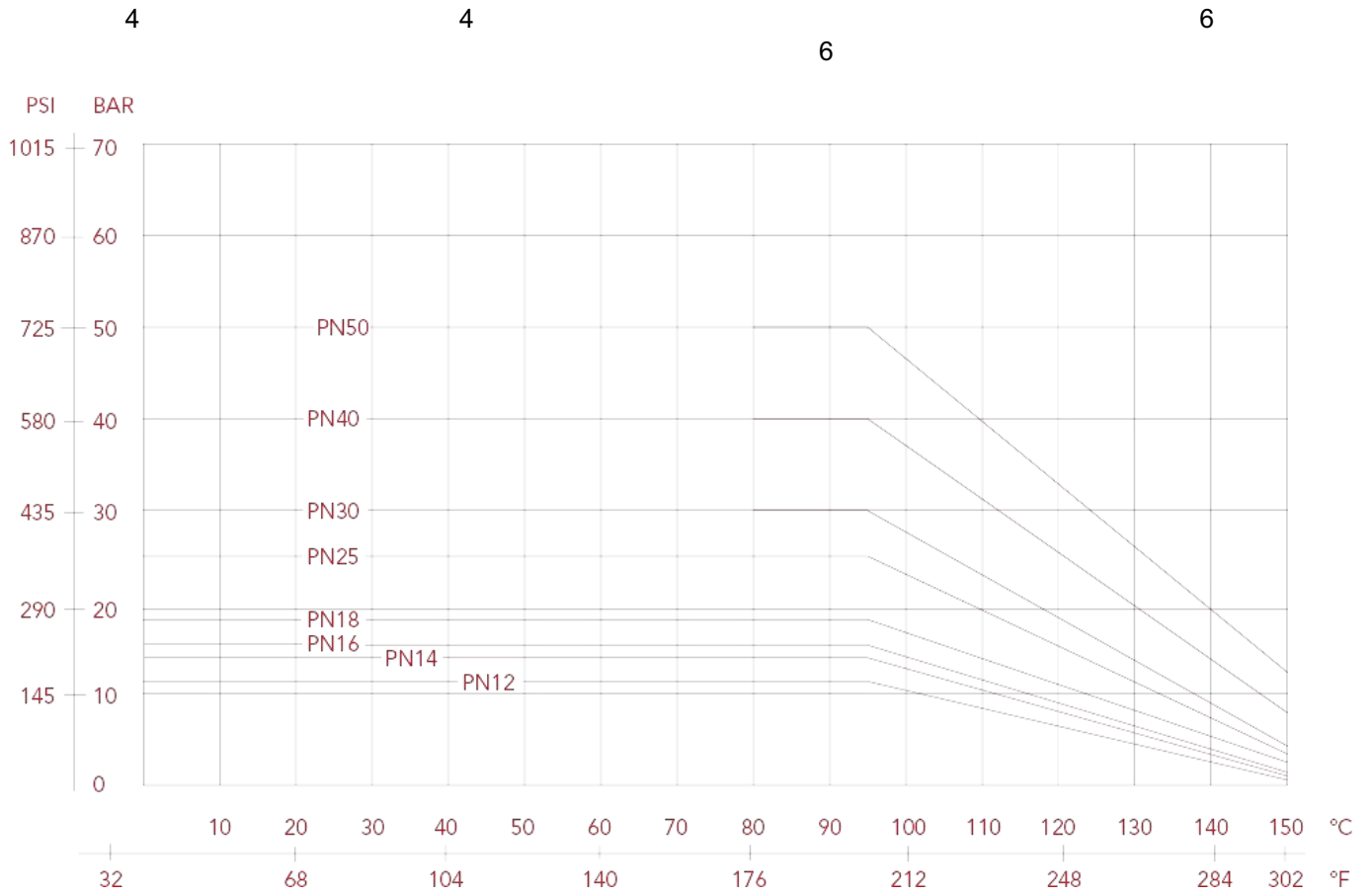



GbTVPe

ГВМРП бТВPe 4 4 4

6

4

4

4



He			
; 7A OT g : 81	A85AQBE8ППИ	8FE88; AmT S R	E7C
9(OT g : B1	A85AQBE8ППИ	8FE8988mT S R	E7C
9(97A OT g ; : 1	; 85AQ; BППИ	8FE899AmT S R	A7, C



5 6

5

6

6

Gf 8cS49B8cS

6

Gmh :: E0

Tlg Vg brh :: E RmVg brh :: E16

ai G

6

G 7A Ri LL ai 59 Ri LL 97Ai 59 97ARi LL 97.ai 6

R

4

6



GtVPe

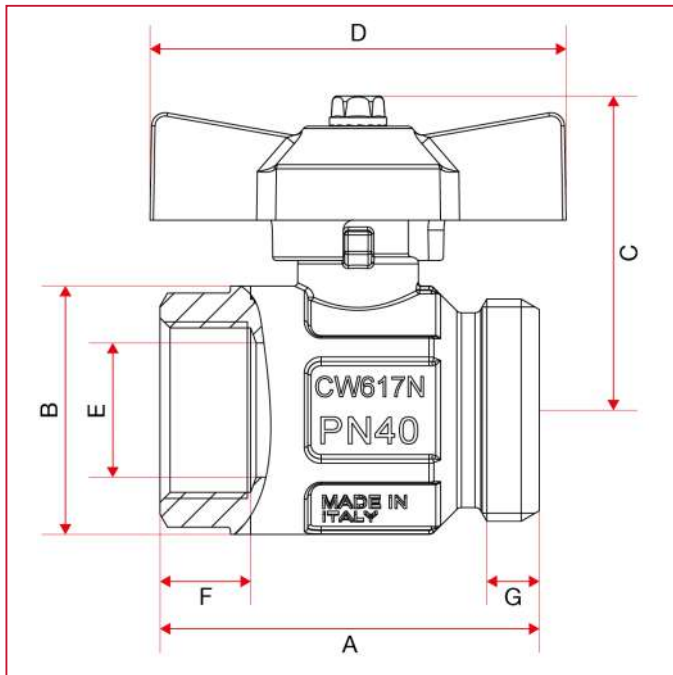

	TDX	P	P(PDX)
Tg	: 8	: B	: :
P	BCB	CA/DB	DC
R	; D	AB/B	BD
S	AD	B8/E	CA
T	C	C	D8
V	: 8	: B	: :
W	9; 4B	9B	9C/B
X	E	98/B	9A
dЖЕМ: БAC	A8	A8	: 8
eRm5ПТМ	BE8	BE8	A; B



GbTVPe

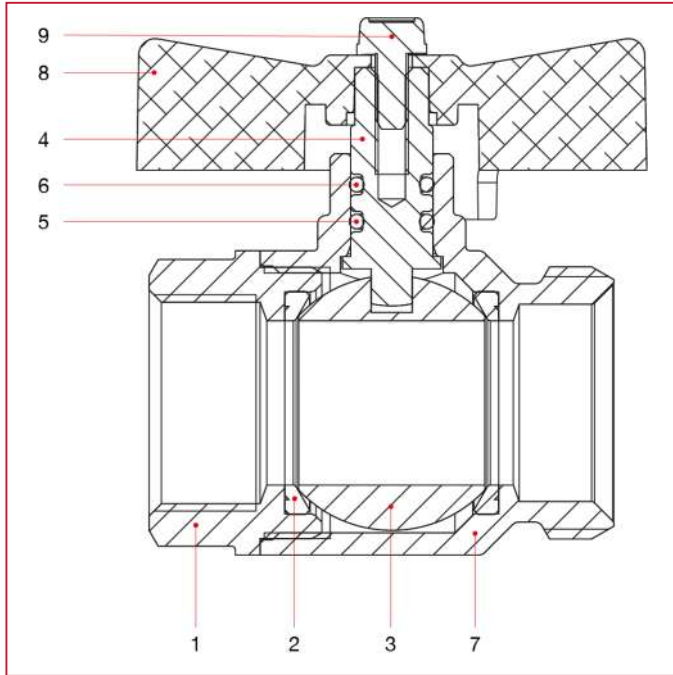

g6		6	
9		9	Sr C9Dg
:		:	
;		9	Sr C9Dg
A		9	Sr C9Dg
B		9	Sr C9Ag
C		9	
D		9	pXCh
E	5	9	
F		9	SAS



GbTVPe

lnPi 4 4 6 4
4 4 4 4
4 4 6 4
4 4 4 4
5 4 0 4 1 4 4 4 4 4 4
5 4 0 4 4 4 4 4 4 4
5 6 4 4 4 4 4 4 4 4
5 4 4 4 4 4 4 4 4 4
5 5 5 5 5 4 4 4 4 4
5 H 4 4 4 4 4 4 4 4
5 6 4 4 4 4 4 4 4 4



GtVPe

3 4

dp	; 7A : C4 C	9(A94AA	9(97A C, 4CF
----	----------------	-------------	-----------------

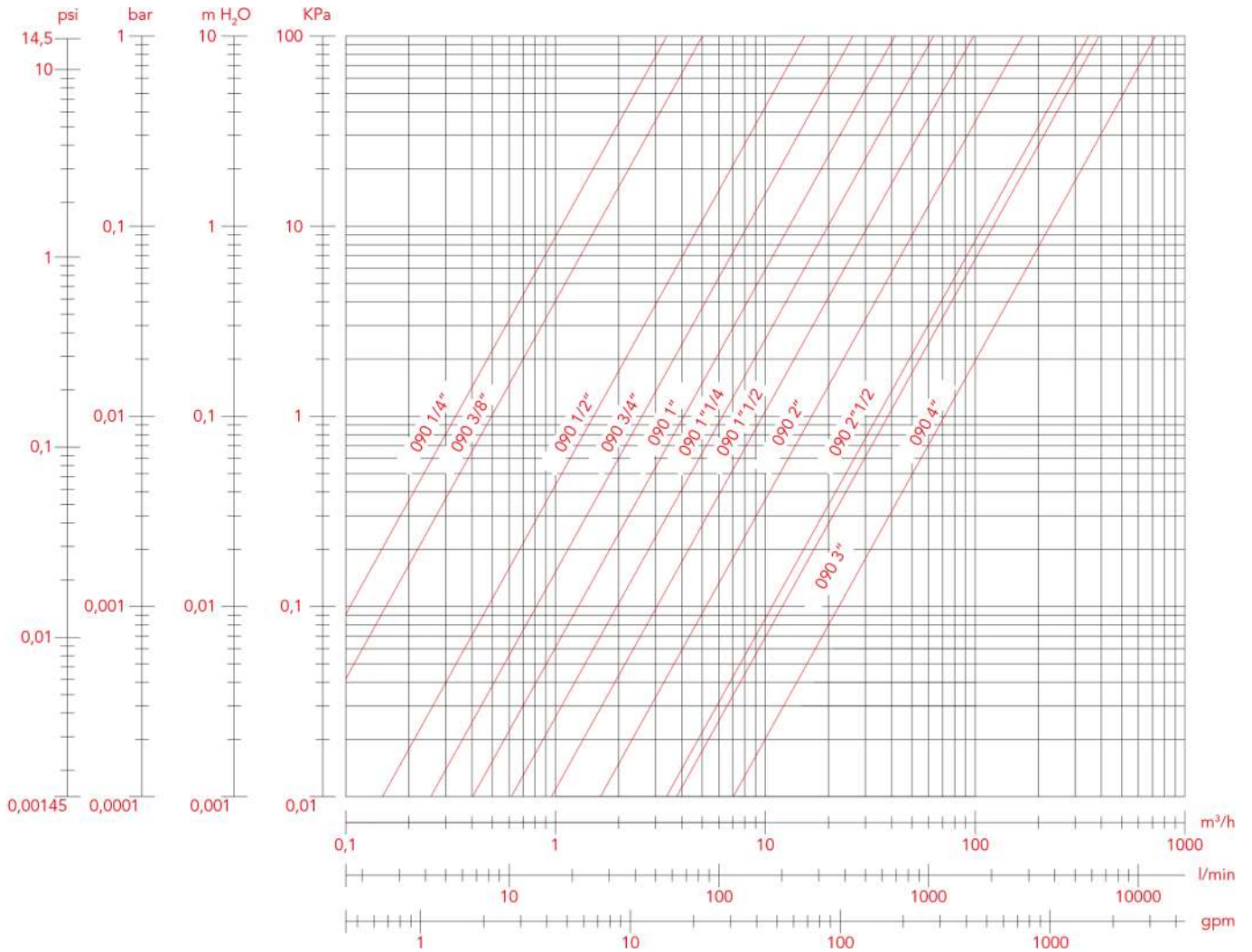



GtVPe

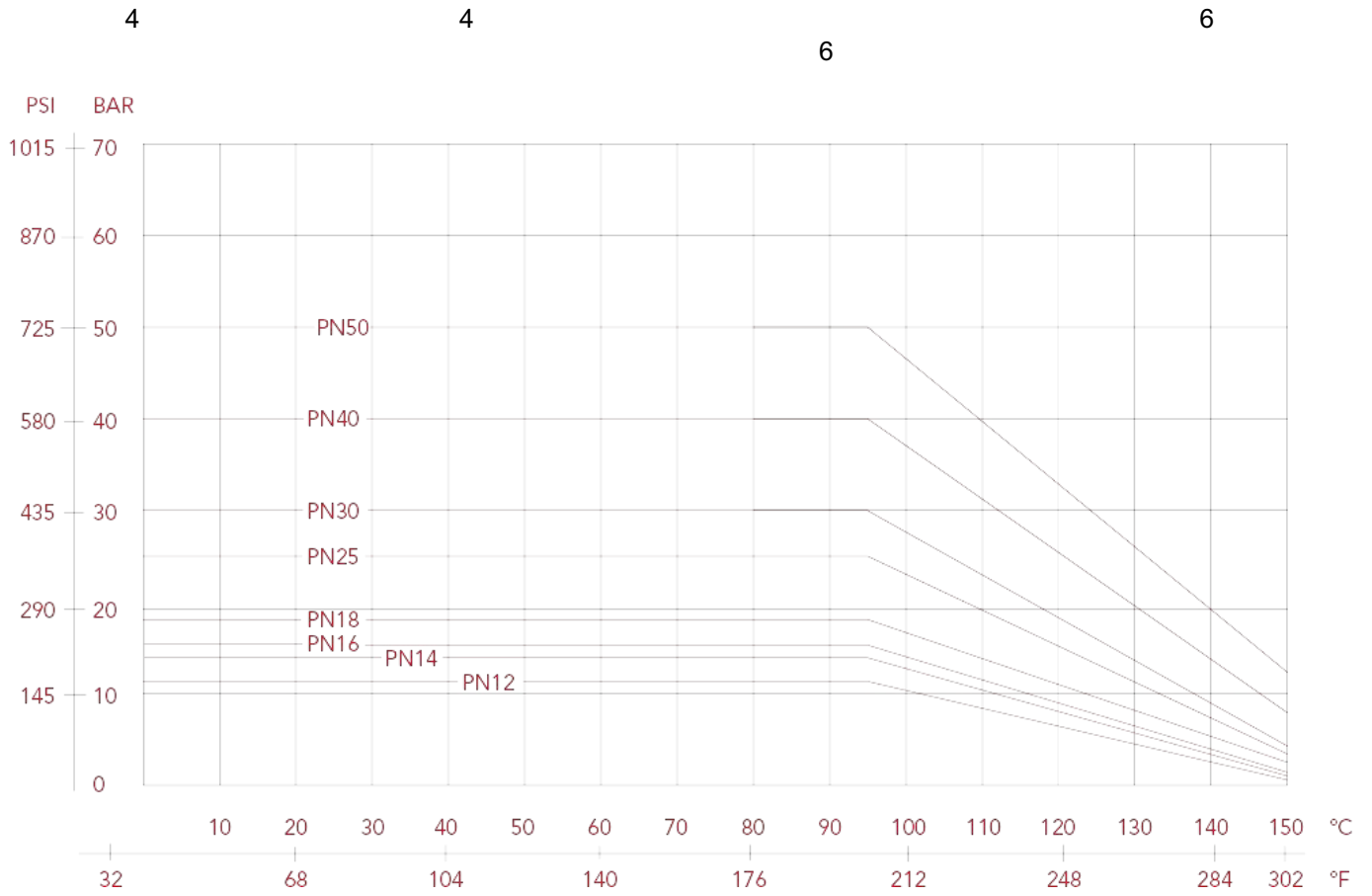



GbT VPe

СГБ GbT VPe

4

4

6

4

4

4



ψHe

97. (OTg 9B1	B8BAQD: BИTИ	: FE889:	CTEA
; 7A(OTg : 81	A8BAQBE8ITИ	: FE88; A	CTA:
9(OTg : B1	A8BAQBE8ITИ	: FE8988	A7. A



5 6

5

6

6

Gb 8cS49B8cS

6

Gmh :: E0

Tlg Vg brh :: E RmVg brh :: E16

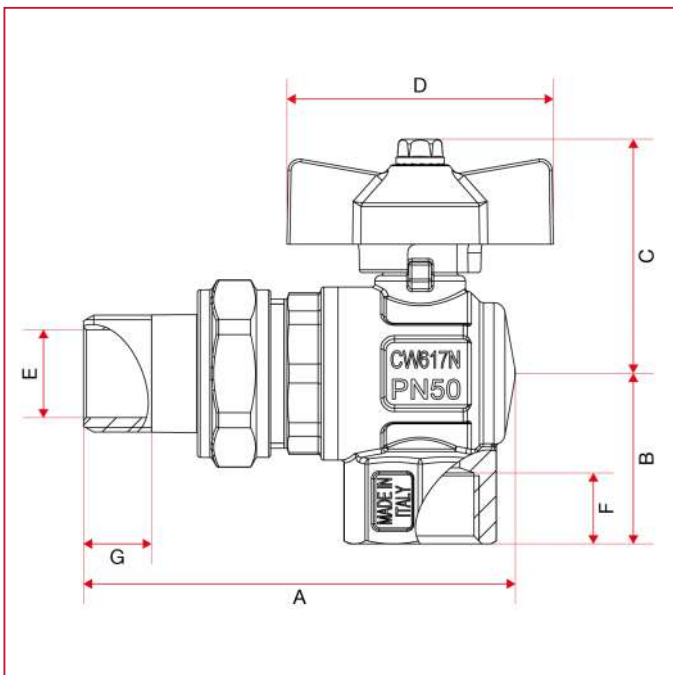



GbT VPe

	PLS(TDX(P(
Tg	9B	: 8	: B
P	DC4	EF4B	98C4B
R	; 8	; ; 4B	; F4DB
S	A9	AD	B9
T	AD	C.	C.
V	9A	9E	::
W	9: 4B	9; 4B	9B
X	9:	9A	9C
dЖEM: БAC	B8	A8	A8
eRm5ПТТ	D: B	BE8	BE8

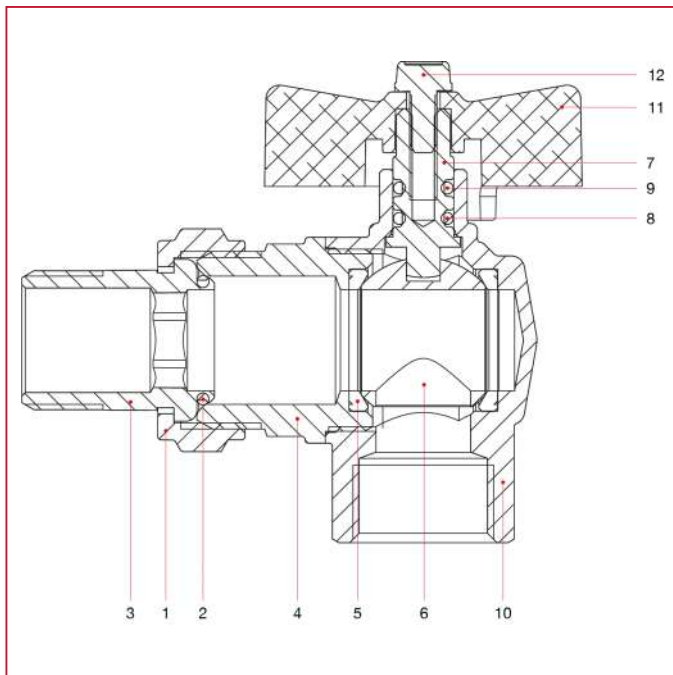

g6		6	
9		9	Sr C9Dg
:		9	
;		9	Sr C9Dg
A		9	Sr C9Dg
B		:	
C		9	Sr C9Dg
D		9	Sr C9Ag
E		9	
F		9	pXCh
98		9	Sr C9Dg
99	5	9	
9:		9	SAS



GbTVPe

3 4

dp	97 (; 7(9(
	C	9:	9F4

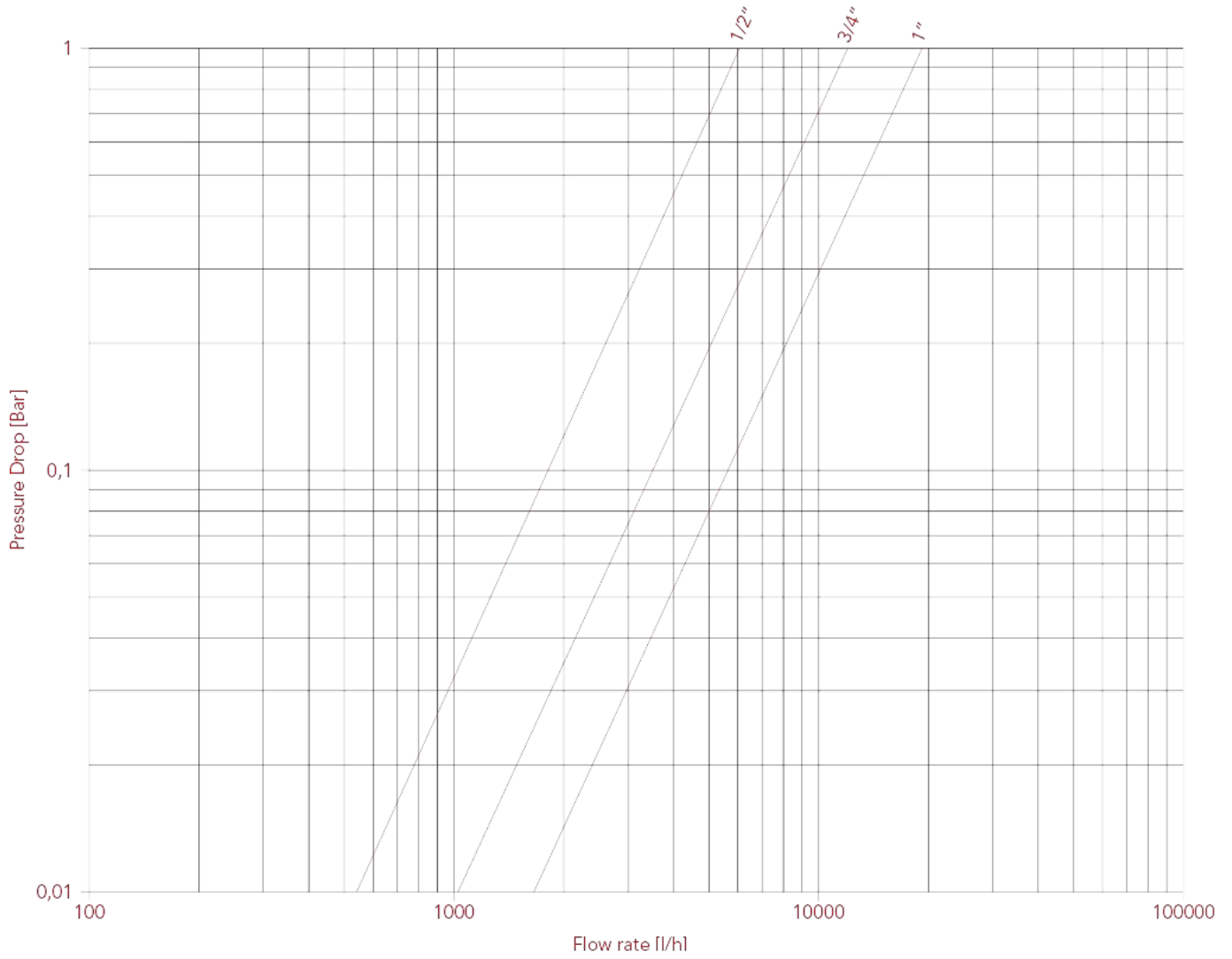



GtVPe

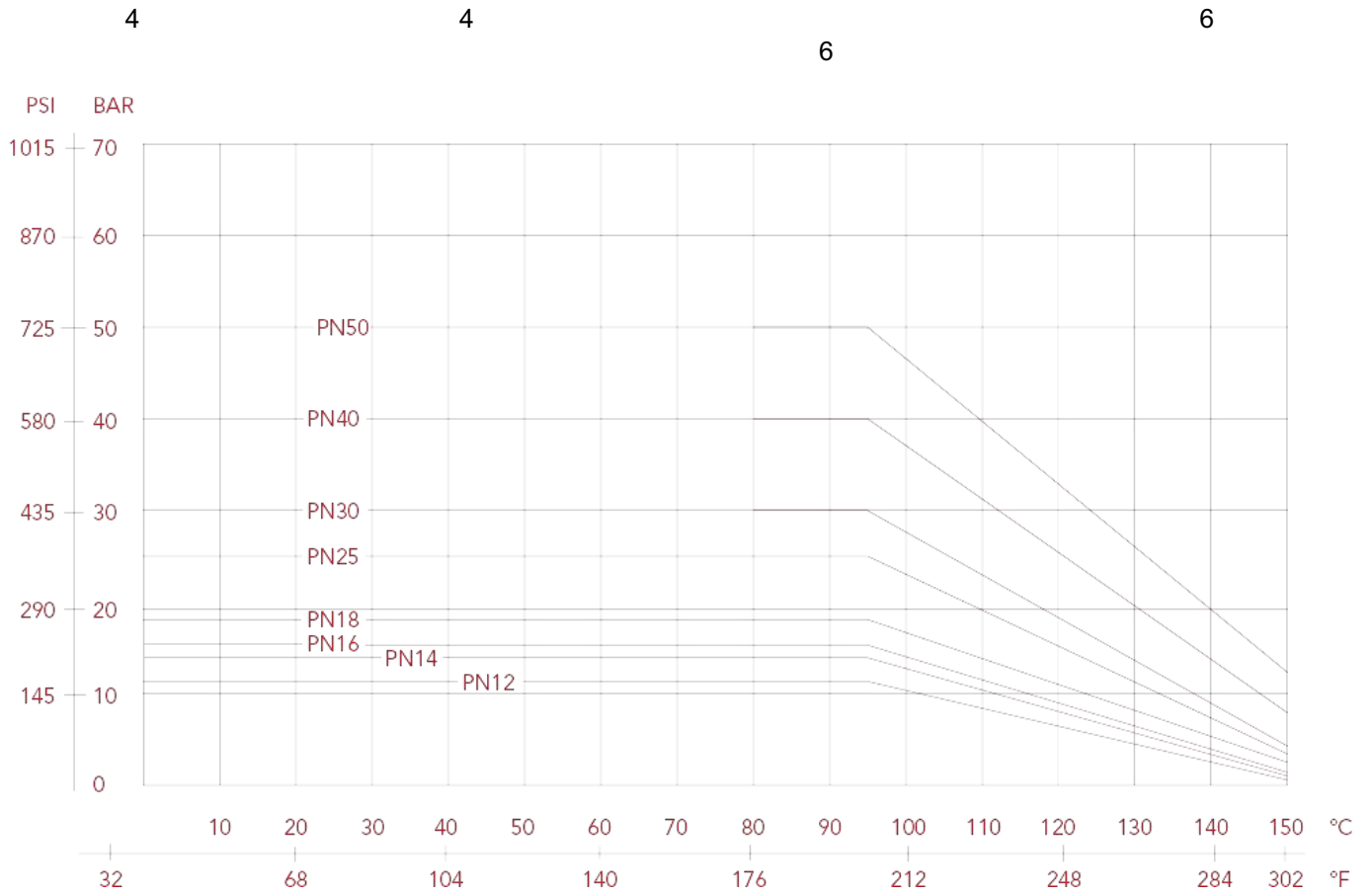



GbT VPe

СГБм GbT VPe 4 4 4

6

4

4

4

ψHe

97. (Gg 9B1	B8BAQD: BИTИ	: FE889: m	CTEA
; 7A(Gg : 81	A8BAQBE8ИTИ	: FE88; Am7mR	CTA:
9(Gg : B1	A8BAQBE8ИTИ	: FE8988m7mR	A7. E



5 6

5

6

6

Gf 8cS49B8cS

6

Gmh :: E0

Tlg Vg brh :: E RmVg brh :: E16

; 7A 9 G mR 4

6



GbTVPe

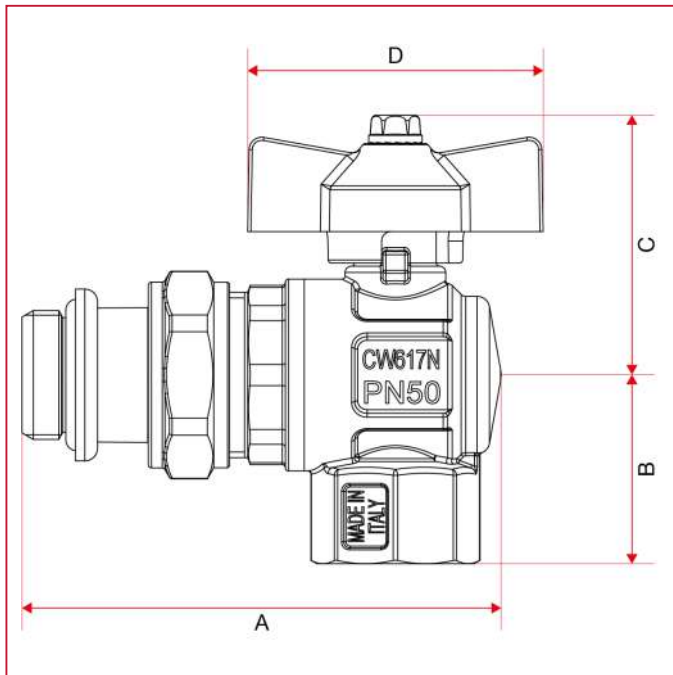

	PLS(TD(P(
Tg	9B	: 8	: B
P	DC4	EF4B	98B4B
R	; 8	; ; 4B	; F4DB
S	A9	AD	B9
T	AD	C.	C.
d)ЖЕМ: БАС	B8	A8	A8
eRm5ПТТ	D. B	BE8	BE8



G6T VPe

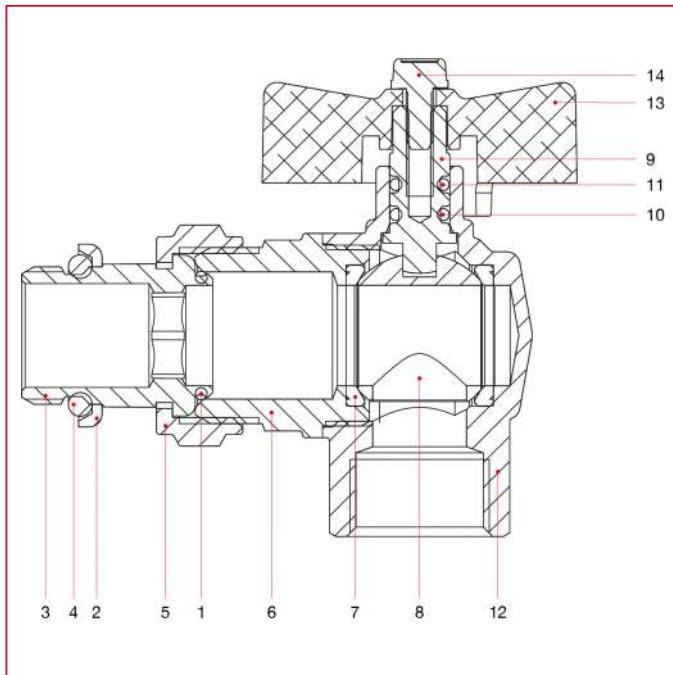

g6		6	
9		9	
:		9	
;		9	Sr C9Dg
A		9	
B		9	Sr C9Dg
C		9	Sr C9Dg
D		:	
E		9	Sr C9Dg
F		9	Sr C9Ag
98		9	
99		9	pVCH
9:		9	Sr C9Dg
9;	5	9	
9A		9	SAS



GbTVPe

lnPi 4 4 6 4
4 4 4 4
4 4 6 4
4 4 4 4
5 4 0 4 1 4 4 4 4 4 4
5 4 0 4 4 4 4 4 4 4
5 6 4 4 4 4 4 4 4 4
5 4 4 4 4 4 4 4 4 4
5 4 4 4 4 4 4 4 4 4
5 4 4 4 4 4 4 4 4 4
5 H 4 4 4 4 4 4 4 4
5 4 4 4 4 4 4 4 4 4
5 4 4 4 4 4 4 4 4 4
5 H 4 4 4 4 4 4 4 4
5 4 4 4 4 4 4 4 4 4



GbTVPe

3 4

dp	97 (; 7(9(
	C	9:	9F4

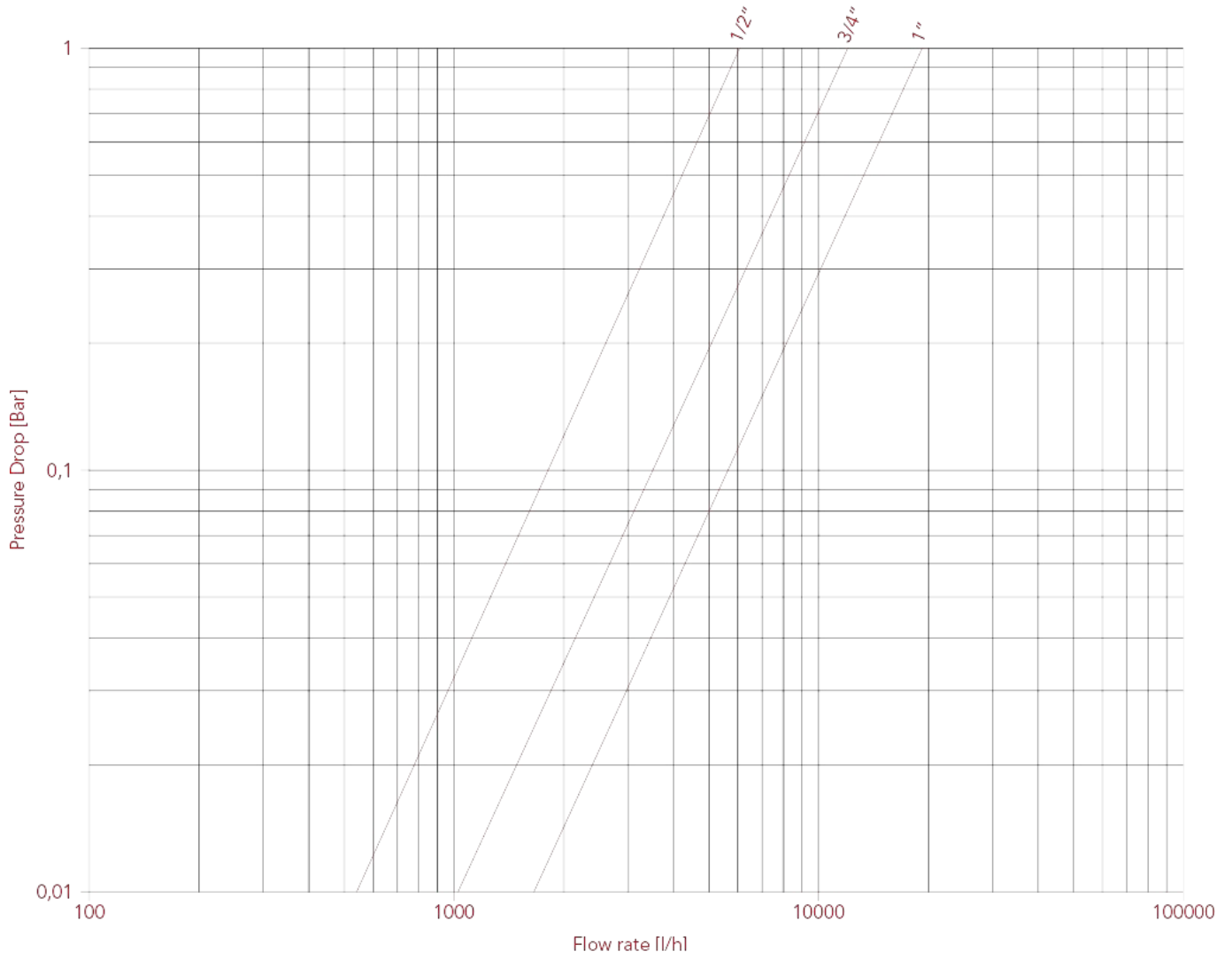



GtVPe

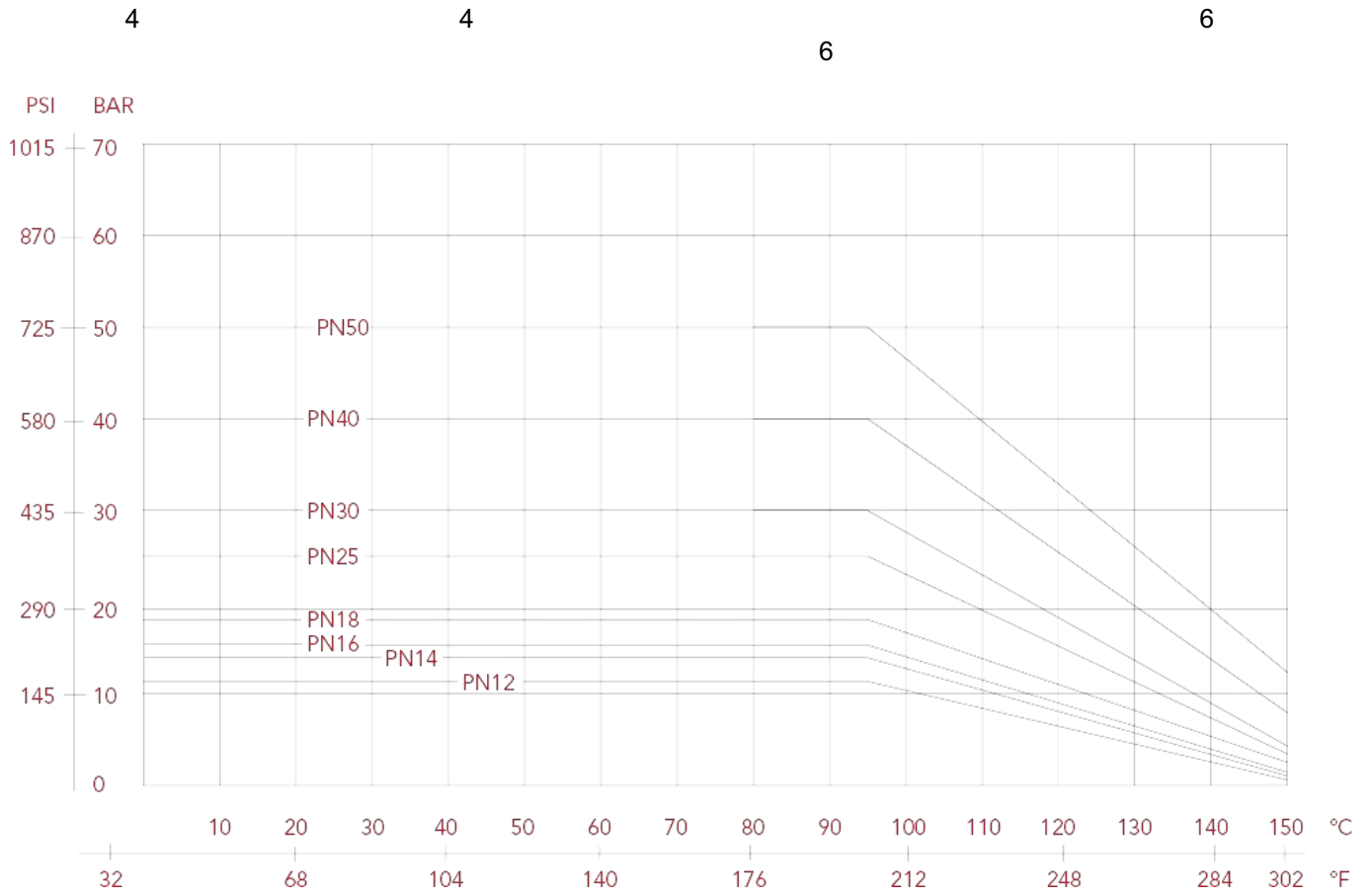



GbTVPe

СГВМРП бТВРР

4

4

4

6

4

4

4



ψHe

; 7(0Tg : 81

A85AQBE8ΠΠΠ

: FE88; AmT S7R

C7BA

9(0Tg : B1

A85AQBE8ΠΠΠ

: FE8988mT S7R

A7AA

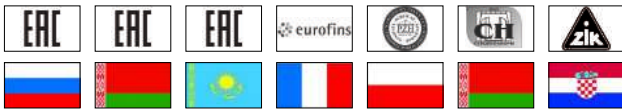

5 6

5

6

6

Gf 8cS49B8cS

6

Gmh :: E0

Tlg Vg brh :: E RmVg brh :: E16

ai G

6

G 7A Ri W9 ai 59 Ri W9 97Ai 6

R

4

6



GbTVPe

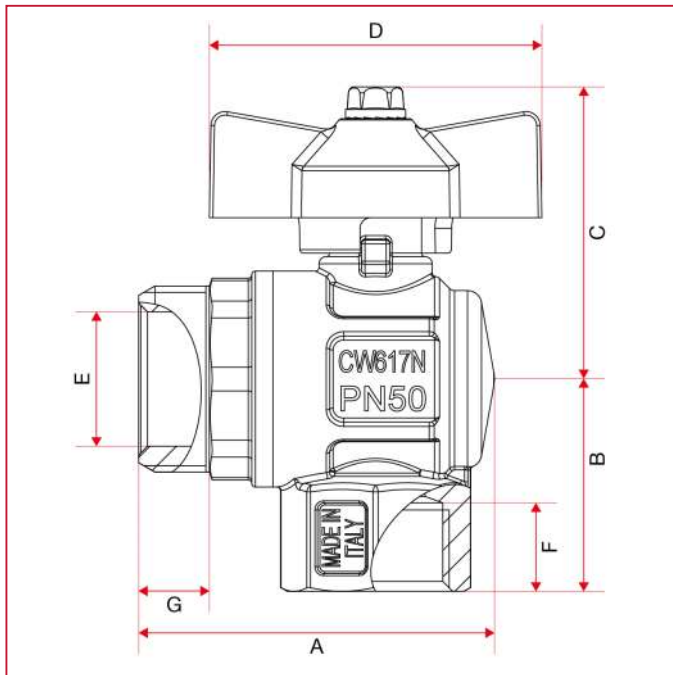

	TDX(P(
Tg	: 8	: B
P	A8	AD
R	; ; 4B	; F4DB
S	AD	B9
T	C.	C.
V	9E	: ;
W	9; 4B	9B
X	9:	9A
d)ЖЕМ: БАС	A8	A8
eRm5ПТИ	BE8	BE8



G6T VPe

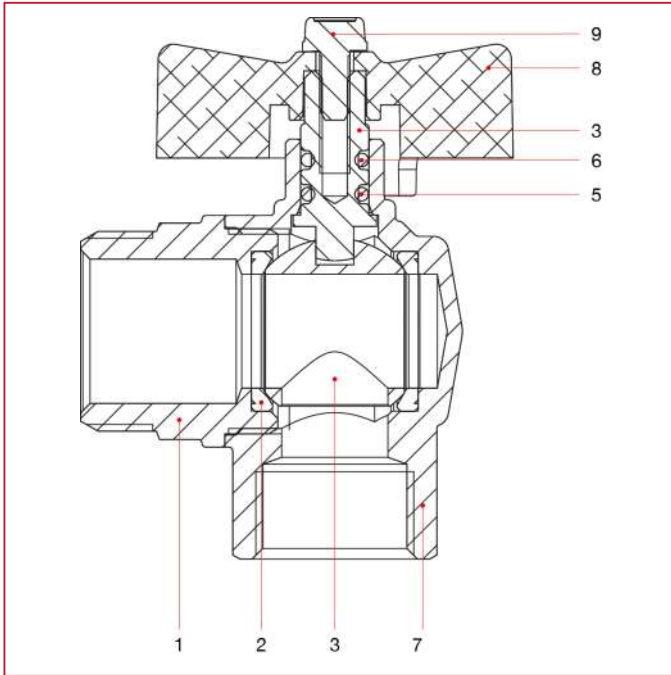

g6		6	
9		9	Sr C9Dg
:		:	
;		9	Sr C9Dg
A		9	Sr C9Ag
B		9	
C		9	p10Ch
D		9	Sr C9Dg
E	5	9	
F		9	SAS



GtVPe

3 4

dp		
	; 7(9(
	9:	9F4

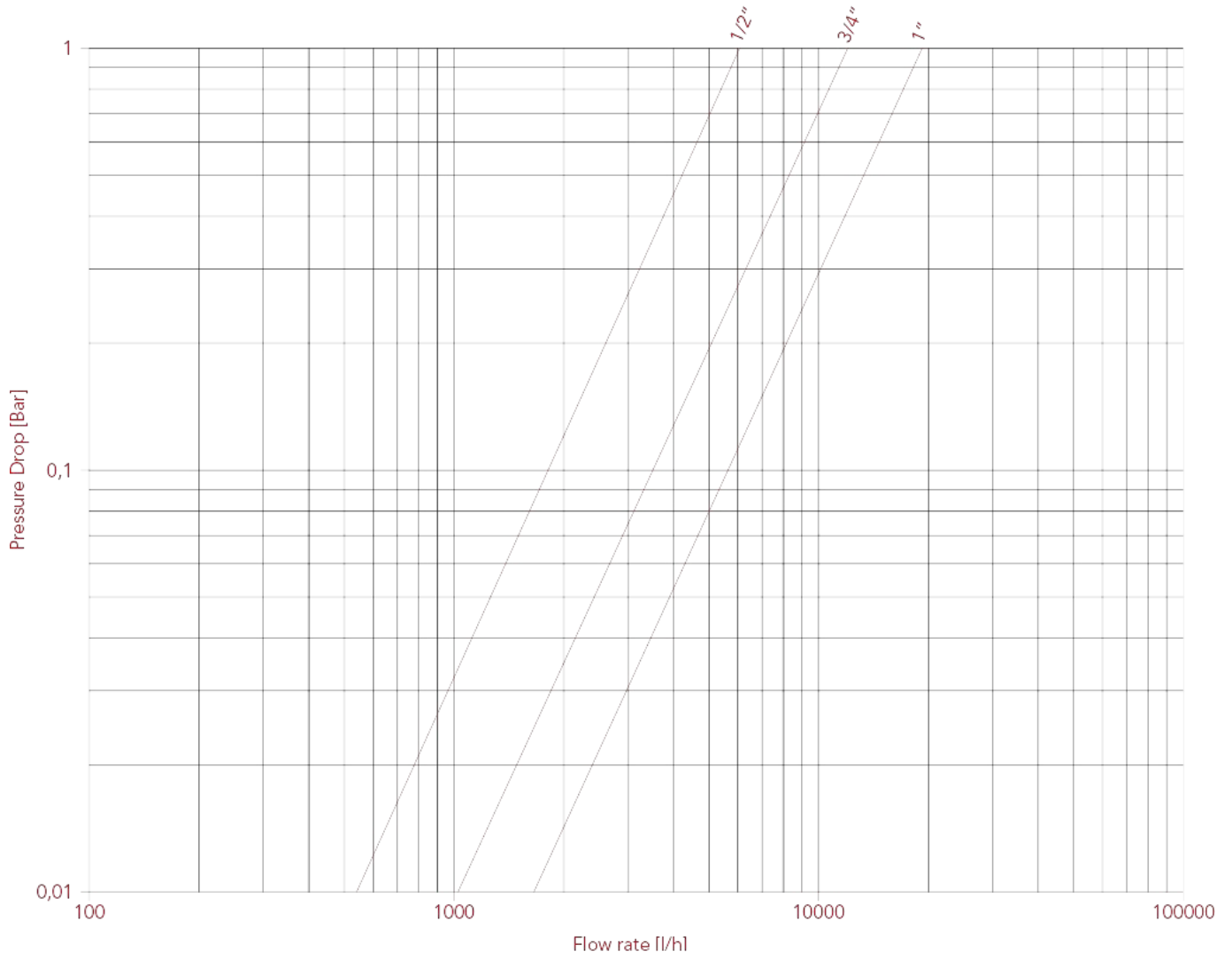



GtVPe

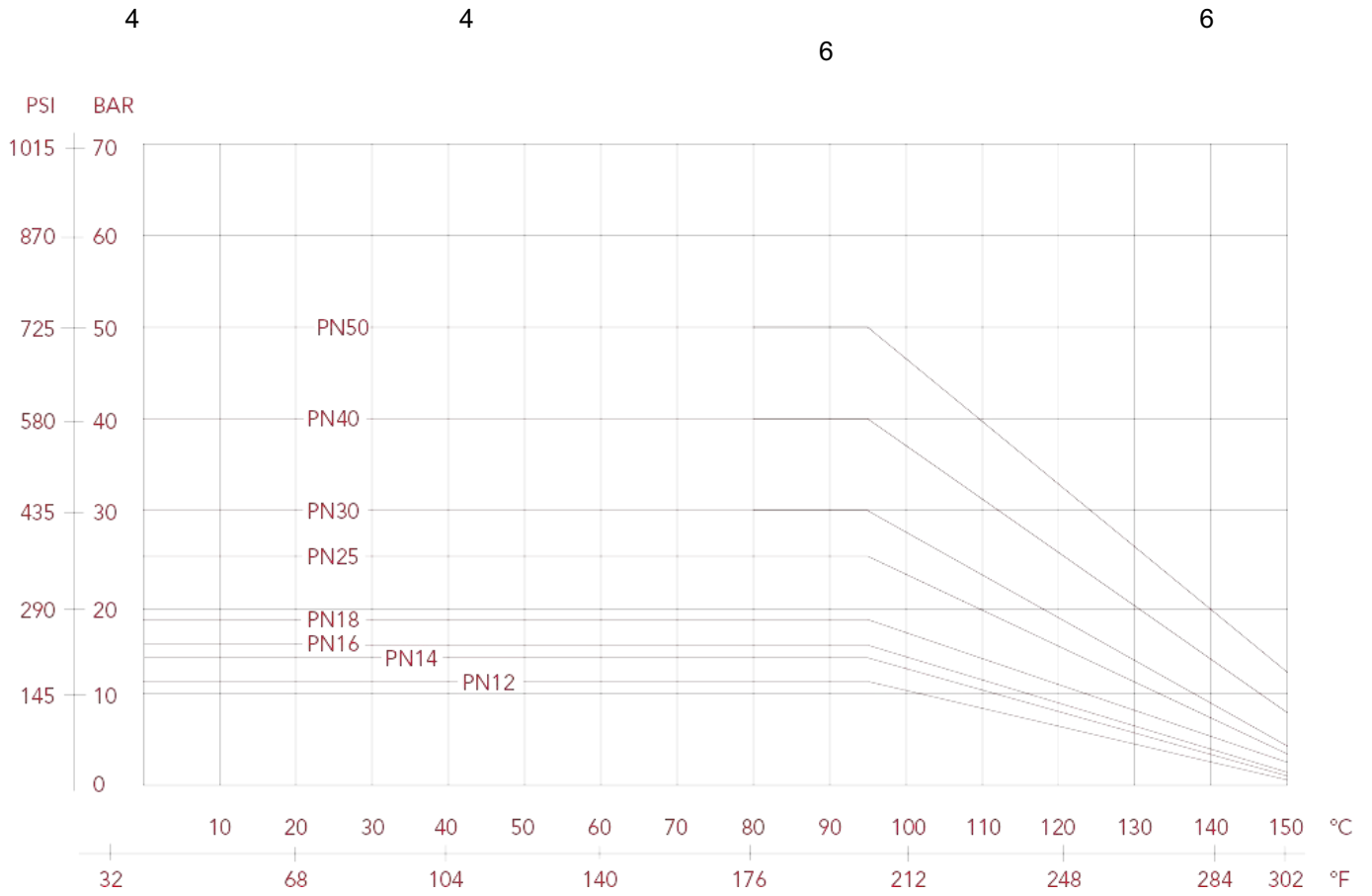



GbTVPe

ХГСОП



		ЏHe	
9(0Tg : B1	98БAC9ABITИ	AF: 8988RS	A7C8
9(97A 0Tg ; : 1	98БAC9ABITИ	AF: 899ARS	A7BC



68FEmT S4 6: FEmT S6
6

h 5 g RI 6
G8cS4E8cS6
GA8 6

GE8cS6
Gmh :: E 0 Tlg Vg brh :: E RmVg brh :: E16

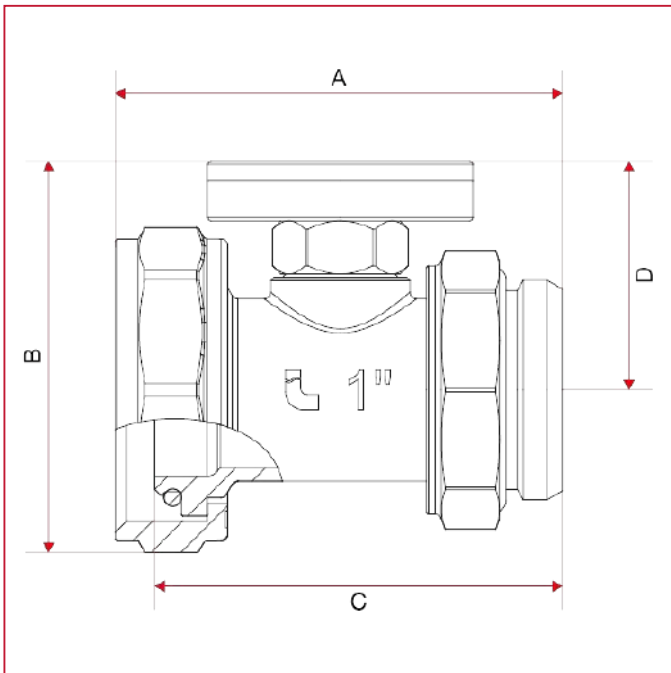



GbT VPe

	P{	P{ PDX
P	C04B	DF4B
R	AF	BB
S	C04B	D;
T	; A4B	; F
dЖEM: БAC	98	98
eRm5ПТМ	9AB	9AB

P{

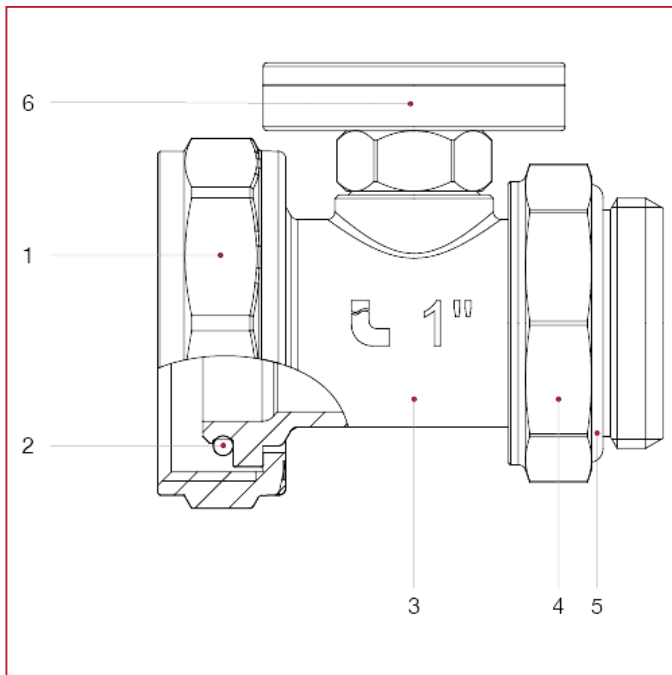

g6		6	
9		9	Sr C0Dg
:		9	
;		9	Sr C0Dg
A		9	Sr C0Dg
B		9	
C		9	Sr C0Ag



P(PDX)

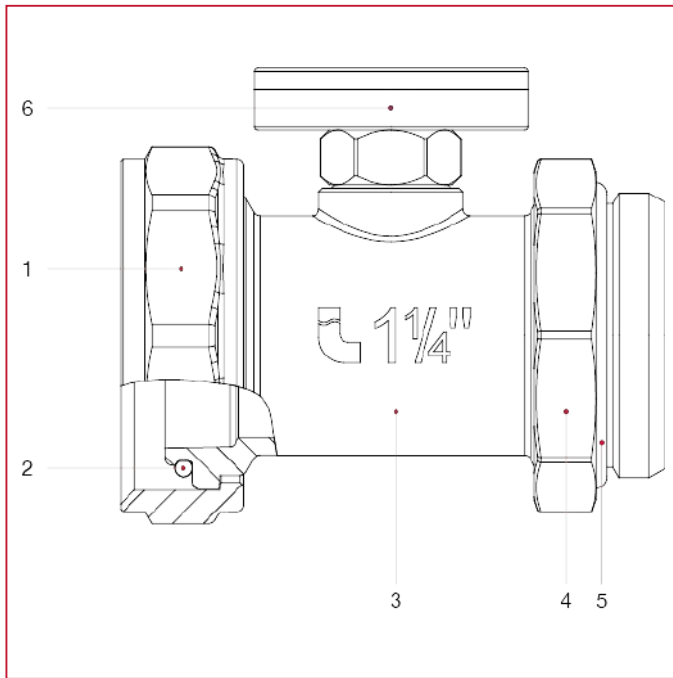

g6		6	
9		9	Sr C9Dg
:		9	
;		9	Sr C9Dg
A		9	Sr C9Dg
B		9	
C		9	Sr C9Ag



ITAP S.p.A.
Via Ruca 19
25065 Lumezzane
Brescia (ITALY)
Tel 030 8927011
Fax 030 8921990
www.itap.it - info@itap.it

г д өтдөхд үзд ожуу уо мақд
имгөхдмднүт аңг вэаиңдт уо үзд
посфвүт гдтвөбдг здсднн аңг уо үзд
сдлаужд үдвэнивалгауаа ау аны уимд аңг
чжвсфүесдчасниж